

AUTOMATIC STRAPPING MACHINES



INNOVATIVE HIGH SPEED STRAPPING MACHINE

SM65 Series

SM65 is an innovative world-class high speed automatic strapping machine. It is suitable for 5 mm, 6 mm, 3/8 (9 mm), or 1/2 (12 mm) PP strapping. Equipping with all industry's standard features and creative user friendly designs, SM65 offers the most optimal performance, highest speed, easiest maintenance, and the most cost effective solution in its class.

SM65 - 5 mm, 6 mm, 3/8 (9 mm)



SM65 - 1/2 (12 mm)



Main Features

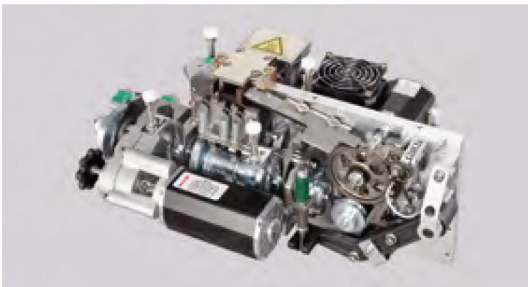

Robust and Compact Strapping Head

Use the latest brushless DC motor direct drive technology to provide the highest level of accuracy and reliability. All motors are German-made. Without belts, clutches, and pulleys, its compact design greatly minimizes the numbers of moving parts and maintenance cost.



Free Access to Strap Guides (patents registered)

Hinged top plate makes easy access to the strapping head for quick maintenance. Unblocking the guides enables free and quick access to strap guides without using any tools. The most maintenance friendly design.



Waist-High Auto Strap Feeding

Friendly design to feed the strap automatically from the upper side of the coil without the need to access to the bottom of the machine.



Waist-High Quick Coil Change (patents registered)

Innovative waist-high coil change without access to the bottom of the machine. Quick release lock eliminates downtime to change the coil. Ergonomic and quick change design makes coil change simpler than ever.

INNOVATIVE HIGH SPEED STRAPPING MACHINE

More Features

Sensor Controlled Heater

The fast heating mechanism is sensor controlled assuring consistent and high sealing efficiency.

Low Voltage

All DC motors and heater are "stepped down" to 24V to increase the safety of the machine.

Strap End Ejector

Eject the end of strap from the inlet of strap feeding. Easy to clean the end of strap and get the machine ready for next coil of strap.

Front Foot Bar Switch

Standard front foot bar switch makes machine operation in a very easy way. Ergonomic cycle initiation design and user friendly.

Dispenser Release Switch

Friendly design makes it easier to pull the strap from the strap dispenser for waist-high auto strap feeding.

Adjustable Table Height

The table height is adjustable to any height between 820 mm and 920 mm.

Turnable Operating Control Panel

The turnable operating control panel with LCD display is located on upper side of the machine for easy access. It enables machine operation from both front and rear sides. User friendly.

Auto Strap Ejector

Loop-ejector clears unwanted strap automatically if the machine is accidentally activated without a package.

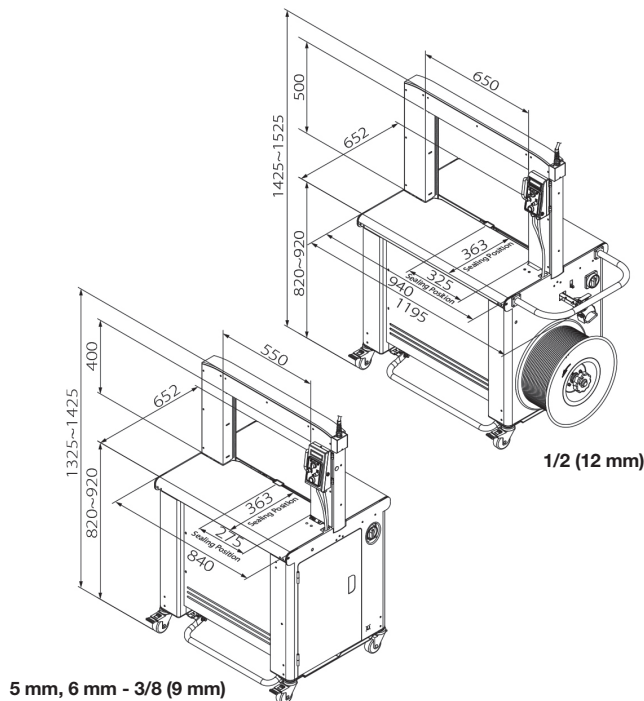

Options

- Photo-eye switch
- Rear foot bar switch
- Foot pedal switch
- Lower adjustable table height 30.31"-32.28" (770 mm - 820 mm)
- Selected parts in stainless steel
- Stainless steel frame SUS 304

Arch Sizes

SM65 (for 5 mm, 6 mm, or 3/8 (9 mm) strap)

H \ W	21.6" 550 mm	25.5" 650 mm	33.4" 850 mm	41.3" 1050 mm	49.2" 1250 mm	64.9" 1650 mm	72.8" 1850 mm
15.7"/400 mm	Ⓢ		✓				
19.7"/500 mm		✓	✓	✓	✓	✓	
23.6"/600 mm			✓				
31.5"/800 mm			✓	✓	✓		✓
39.4"/1000 mm				✓	✓		

Ⓢ Standard size: 550 mm (W) x 400 mm (H)

- ✓ means available arch size

SM65 (for 1/2 (12 mm) strap)

H \ W	25.5" 650 mm	33.4" 850 mm	41.3" 1050 mm	49.2" 1250 mm	64.9" 1650 mm	72.8" 1850 mm	80.7" 2050 mm	88.6" 2250 mm
15.7"/400 mm		✓						
19.7"/500 mm	Ⓢ		✓		✓		✓	
23.6"/600 mm		✓	✓	✓				✓
31.5"/800 mm		✓	✓	✓		✓		
39.4"/1000 mm		✓	✓	✓				
47.2"/1200 mm			✓					

Ⓢ Standard size: 650 mm (W) x 500 mm (H)

- ✓ means available arch size

Technical Data

Capacity	Up to 65 cycles/minute (5 mm, 6 mm, 9 mm) Up to 60 cycles/minute 1/2 (12 mm)
Strap Width	5 mm, 6 mm, or 3/8 (9 mm), 1/2 (12 mm)
Tension Range	1 - 32 kg (1-70.5 lbs.) 1 - 45 kg (1-99.21 lbs.) (Higher tension is on request)
Weight	350 lbs.
Electrical Requirements	110V, 220V, 230V, 240V 50/60Hz 1PH
Core Size	8x8

HIGH SPEED STRAPPING MACHINE WITH DUAL PNEUMATIC PRESS

SM65-WC

SM65-WC (with dual press) is built based on SM65. It carries all the innovative features and user friendly designs of SM65. SM65-WC is ideal for strapping compressible material such as corrugated papers, paper sheets, corrugated boxes, plastic sheets, bags, etc.

SM65-WC

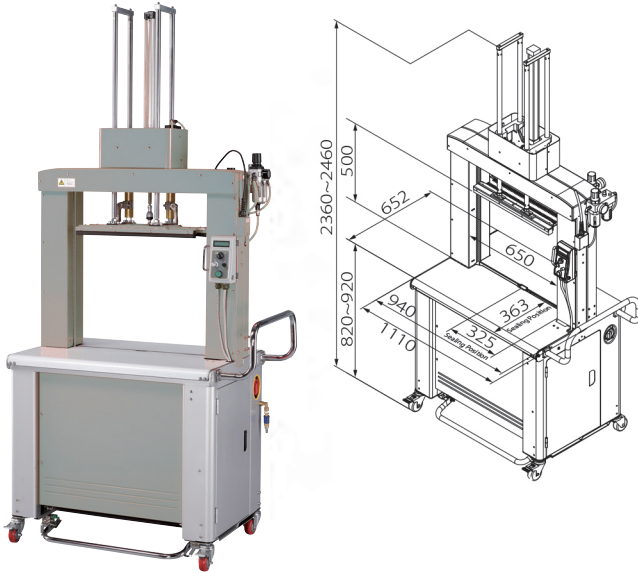

SM65-WC-

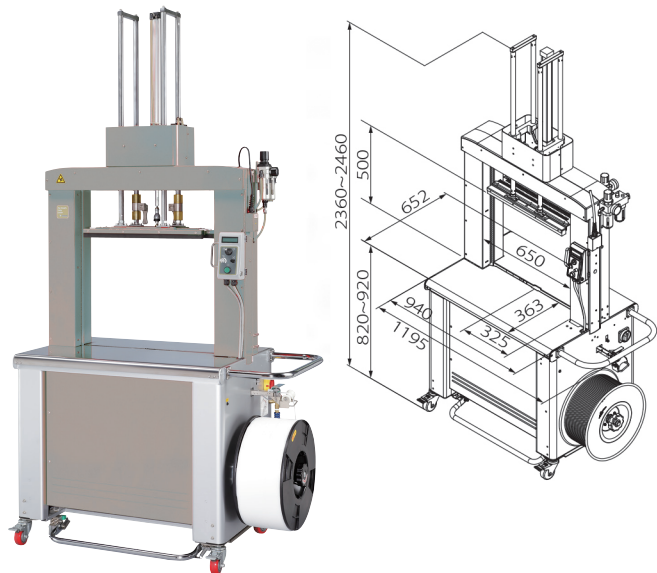

More Features

Robust and Compact Strapping Head

Use the latest brushless DC motor direct drive technology to provide the highest level of accuracy and reliability. All motors are German-made. With compact design and fewer moving parts, it can greatly minimize the maintenance cost.

Dual Pneumatic Press

Ideal for strapping compressible package for better product stability and containment.

Free Access to Strap Guides (patents registered)

Unblocking the guides enables free and quick access to strap guides without using any tools. The most maintenance friendly design.

Options

- Photo-eye switch
- Rear foot bar switch
- Foot pedal switch
- Lower adjustable table height 30.31"-32.28" (770 mm - 820 mm)
- Safety guards
- Stainless steel frame SUS 304

Arch Sizes

H \ W	25.5"/650 mm	33.4"/850 mm	41.3"/1050 mm	49.2"/1250 mm	64.9"/1650 mm
19.7"/500 mm	Ⓢ			✓	✓
23.6"/600 mm		✓			
31.5"/800 mm			✓	✓	

Ⓢ Standard size: 650 mm (W) x 500 mm (H)

• ✓ means available arch size

• Arch size: 1250 mm (W) x 500 mm (H) is only for SM65-WC

Technical Data

Capacity	Up to 47 cycles/minute 3/8 (9 mm) Up to 44 cycles/minute 1/2 (12 mm)
Strap Width	5 mm, 6 mm, or 3/8 (9 mm) 1/2 (12 mm)
Tension Range	1 - 32 kg (1-70.5 lbs.) 1 - 45 kg (1-99.21 lbs.) (Higher tension is on request)
Weight	495 lbs.
Electrical Requirements	110V, 220V, 230V, 240V 50/60Hz 1PH
Core Size	8x8

HIGH SPEED STRAPPING MACHINE FOR SMALL OR ROUND PACKAGES

SM65-SSH

Suitable for small or round packages such as plastic pipes, steel rod, hardwood, etc. It can strap packages as small as 40 mm (W) x 10 mm (H) or round packages as small as Ø 32 mm x 2 pieces. SM65-SSH provides reliable high speed performance for small round package applications.

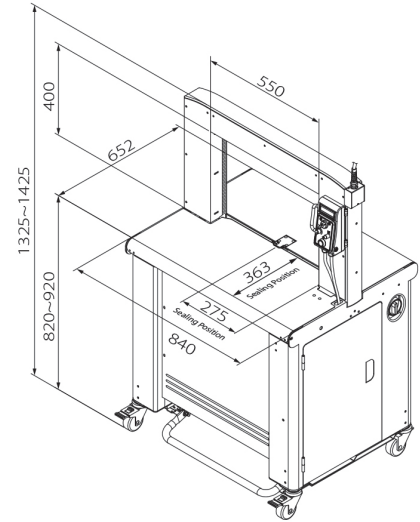

Main Features

Robust and Compact Strapping Head

Use the latest brushless DC motor direct drive technology to provide the highest level of accuracy and reliability. All motors are German-made. With compact design and fewer moving parts, it can greatly minimize the maintenance cost.

Free Access to Strap Guides (patents registered)

Unblocking the guides enables free and quick access to strap guides without using any tools. The most maintenance friendly design.

Waist-High Quick Coil Change (patents registered)

Innovative waist-high coil change without access to the bottom of the machine. Quick release lock eliminates downtime to change the coil. Ergonomic and quick change design makes coil change simpler than ever.

Options

- Photo-eye switch
- Rear foot bar switch
- Foot pedal switch
- Lower adjustable table height 30.31"-32.28" (770 mm - 820 mm)
- Stainless steel frame SUS 304

Package Sizes

Package size	Min.	Max.
Strap width		
5/6 mm	<ul style="list-style-type: none"> □ 40 mm (W) x 10 mm (H) ○ Pipe Ø 32 mm x 2 pcs 	500 mm (W) x 350 mm (H)
9 mm	<ul style="list-style-type: none"> □ 50 mm (W) x 10 mm (H) ○ Pipe Ø 34 mm x 2 pcs 	

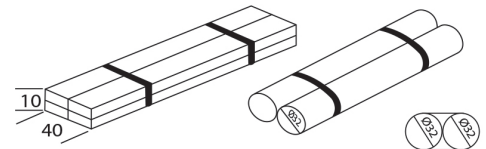

Technical Data

Capacity	Up to 65 cycles/minute
Strap Width	5 mm, 6 mm, or 3/8 (9 mm)
Tension Range	1 - 32 kg (1-70.5 lbs.)
Weight	350 lbs.
Electrical Requirements	110V, 220V, 230V, 240V 50/60Hz 1PH
Core Size	8x8

AUTOMATIC STRAPPING MACHINE

AutoPAC 300

The AutoPAC 300 is a reliable moderate volume applications. At 30 straps per minute it is fast and reliable.

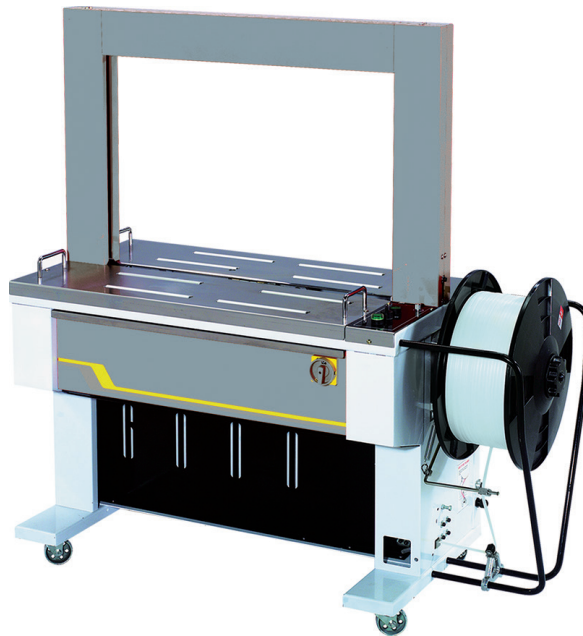

Main Features

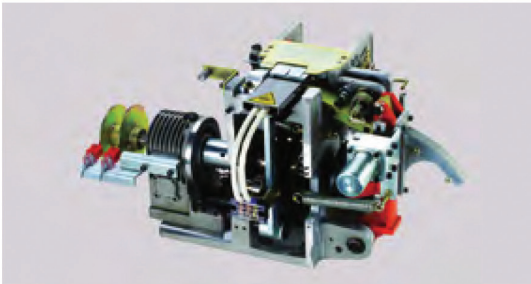

Reliable and Robust Strapping Head

Robust mechanism design and high engineering standard ensure excellent durability of the machine. Use two proximity switches to replace conventional limit switches.



Electronic Tension Control

Strap tension can be adjusted accurately by a simple turn of the dial. Easy operation.



Auto Strap Feeding

Friendly design to feed the strap automatically from the inlet of strap feeding without the need to access to the inside of the machine. Easy strap loading.

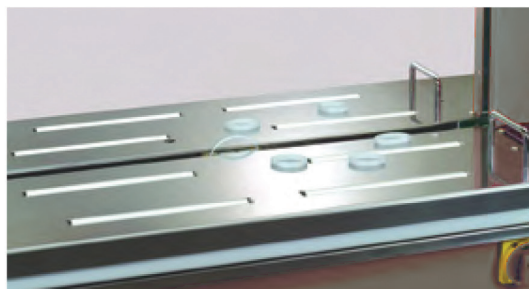

Auto Strap Ejector

Loop-ejector clears unwanted strap automatically if the machine is accidentally activated without a package. Eliminates downtime.

AUTOMATIC STRAPPING MACHINE

More Features

Short Feed Sensor

The sensor detects whether the strap is at sealing position. If not, the strapping cycle cannot be activated.

Auto Strap Refeed

The machine will automatically refeed the strap if a mis-feed occurs.

Strap End Ejector

Eject the end of strap automatically. Easy to clean the end of strap and get the machine ready for next coil of strap.

Multiple Methods of Cycle Initiation

The machine can be operated by several methods, such as foot pedal switch, start switch, and photo-eye switch.

Lubrication Free Strapping Head

No lubrication is required for the strapping head. Therefore, it minimizes the maintenance and saves the cost. Easy maintenance.

Adjustable Weld-Cooling Time

Weld-cooling time is adjustable from 0 to 2 seconds. It ensures the high sealing efficiency when the machine is set at high tension. The adjustment is made based on the quality of PP strapping and the heater temperature.

Options

- Emergency stop switch
- Smoke exhaust system with carbon filter
- Table without free roller
- PU casters
Two free and two with brake. Smooth and silent movement.
- Stainless Steel Frame SUS 304
- The frame is made by SUS 304 stainless steel.
- Provides good protections for the applications in the moist environment. Complete arch can also be made in stainless steel.

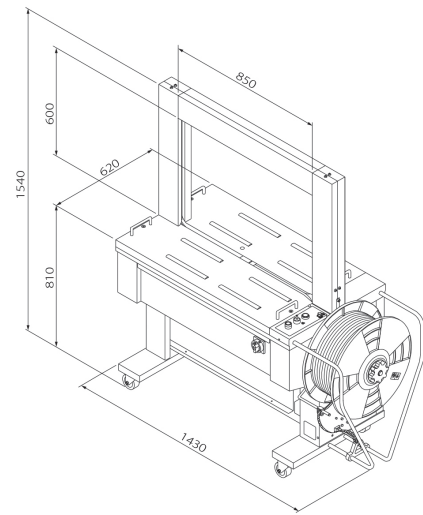

Width >	25.6"	33.4"	41.3"	49.2"	57.0"	64.9"	72.8"
Height	650mm	850mm	1050mm	1250mm	1450mm	1650mm	1850mm
15.7" 400mm							
23.6" 600mm	Standard	Standard					
31.5" 800mm							
39.4" 1000mm							
47.2" 1200mm							

AVAILABLE ARCH SIZES (INCHES/MM) AUTO PAC 300 STANDARD UNITS

- AVAILABLE IN 1/2" AND 3/8" STRAP
- AVAILABLE IN 1/2" HEAVY DUTY STRAP (500LBS. OR GREATER)
- NOT AVAILABLE
REQUIRES A STRAP OF .028" THICK OR GREATER.

Technical Data

Capacity	Up to 29 cycles/minute
Strap Width	1/4 (8 mm), 3/8 (9 mm), or 1/2 (12 mm)
Tension Range	7 - 45 kg *up to 70 kg on request
Maximum Package Weight	220 lbs.
Table Height	31.9"
Weight	485 lbs.
Electrical Requirements	110V, 220V, 230V, 240V 50/60Hz 1PH 220V, 380V, 400V, 415V 50/60Hz 3PH
Core Size	8x8

LOW-TABLE AUTOMATIC STRAPPING MACHINE

AutoPAC 300-L

AutoPAC 300-L is built based on AutoPAC 300. It is designed to work with bulky and heavy packages. Table height is a low 16.14". Safe operation is assured as heavy packages can be strapped easily while keeping lifting effort at a minimum.

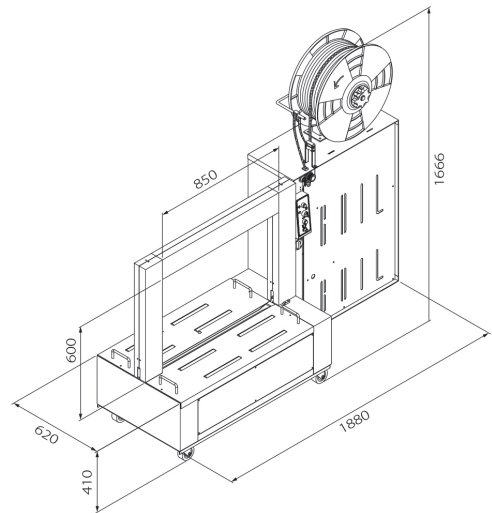

Main Features

Reliable and Robust Strapping Head

Robust mechanism design and high engineering standard ensure excellent durability of the machine. Use two proximity switches to replace conventional limit switches.

Electronic Tension Control

Strap tension can be adjusted accurately by a simple turn of the dial. Easy operation.

Auto Strap Feeding

Friendly design to feed the strap automatically from the inlet of strap feeding without the need to access to the inside of the machine. Easy strap loading.

Auto Strap Ejector

Loop-ejector clears unwanted strap automatically if the machine is accidentally activated without a package.

Short Feed Sensor

The sensor detects whether the strap is at sealing position. If not, the strapping cycle cannot be activated.

Options

- Emergency stop switch
- PU casters (5 free and 2 with brake)

Arch Sizes

H \ W	25.5" 650 mm	33.4" 850 mm	41.3" 1050 mm	49.2" 1250 mm	57.1" 1450 mm	64.9" 1650 mm
15.7"/400 mm	✓	✓	✓	✓	✓	✓
19.7"/500 mm	✓	✓	✓	✓	✓	✓
23.6"/600 mm		✓	✓	✓	✓	✓
31.5"/800 mm		✓	✓	✓	✓	✓
39.4"/1000 mm		✓	✓	✓	✓	✓

- ✓ means available arch size
- More arch sizes are on request

Technical Data

Capacity	Up to 29 cycles/minute
Strap Width	1/4 (8 mm), 3/8 (9 mm), or 1/2 (12 mm)
Tension Range	17 - 45 kg (7-99 lbs.) *up to 70 kg on request
Table Height	16.14" (410 mm)
Weight	235 kg (518 lbs.)
Electrical Requirements	110V, 220V, 230V, 240V 50/60Hz 1PH 220V, 380V, 400V, 415V 50/60Hz 3PH
Core Size	8x8, 9x8