



CP Chicago Pneumatic  
ZAC de la lorie - 38  
rue Bobby Sands 44800 Saint Herblain, France  
www.cp.com

Part no 8940164681  
Issue no 02  
Series no 1  
Date 2010-01  
Page 1

8941076010, 8941076011, 8941076014, 8941076015

## Operator's Manual

### CP7600xB Series Nutrunners



#### WARNING - ATTENTION - ATENCIÓN - ATENÇÃO - ATTENZIONE - VARNING

<b>EN</b>	TO REDUCE THE RISK OF INJURY, BEFORE USING OR SERVICING TOOL, READ AND UNDERSTAND THE FOLLOWING INFORMATION AS WELL AS INCLUDED OR SEPARATELY PROVIDED SAFETY INSTRUCTIONS
<b>FR</b>	POUR RÉDUIRE LES RISQUES DE BLESSURE, AVANT D'UTILISER OU D'ENTREtenir CET OUTIL, LIRE ET COMPRENDRE LES INFORMATIONS QUI SUIVENT AINSI QUE LES INSTRUCTIONS DE SÉCURITÉ JOINTES OU FOURNIES SÉPARÉMENT
<b>ES</b>	PARA REDUCIR EL RIESGO DE SUFRIR LESIONES, ANTES DE UTILIZAR LA HERRAMIENTA DE SERVICIO, POR FAVOR LEA Y COMPRENDA LA INFORMACIÓN SIGUIENTE ASÍ COMO LAS INSTRUCCIONES DE SEGURIDAD QUE SE INCLUYEN ADJUNTAS O SEPARADAS
<b>PT</b>	DE MODO A REDUZIR O RISCO DE ACIDENTES, ANTES DE USAR OU FAZER REPAROS NA FERRAMENTA, LEIA E COMPREENDA AS SEGUINTEs INFORMAÇÕES ASSIM COMO AS INSTRUÇÕES DE SEGURANÇA INCLUÍDAS OU FORNECIDAS EM SEPARADO
<b>IT</b>	PER RIDURRE IL RISCHIO DI INFORTUNI, PRIMA DI UTILIZZARE O SOTTOPORRE A MANUTENZIONE L'UTENSILE, SI PREGA DI LEGGERE E COMPRENDERE LE SEGUENTI INFORMAZIONI E LE NORME DI SICUREZZA IN DOTAZIONE O FORNITE SEPARATEMENTE
<b>SV</b>	FÖR ATT MINSKA RISKEN FÖR SKADOR SKA DU LÄSA OCH FÖRSTÅ NEDANSTÅENDE INFORMATION, SAMT ÄVEN DE SÄKERHETSINSTRUKTIONER SOM MEDFÖLJER ELLER LEVERERAS SEPARAT, INNAN DU ANVÄNDER ELLER UTFÖR SERVICE PÅ VERKTYGET



sales@alcornindustrial.com  
www.alcornindustrial.com  
(800) 317-4775



CP Chicago Pneumatic  
ZAC de la lorie - 38  
rue Bobby Sands 44800 Saint Herblain, France  
www.cp.com

Part no	8940164681
Issue no	1
Series no	1
Date	2019-01
Page	2

8941076010, 8941076011, 8941076014, 8941076015

**FOR DETAILED INFORMATION ABOUT CHICAGO PNEUMATIC  
AIR TOOLS AND EQUIPMENT VISIT OUR WEBSITE**

**[www.cp.com](http://www.cp.com)**



Part no	8940164681
Issue no	02
Series no	1
Date	2019-01
Page	3

## INSTRUCTION MANUAL

This product is designed for installing and removing threaded fasteners in wood, metal and plastic. No other use permitted. For professional use only.

### Main characteristics

Torque range	300 - 900 Nm	221 - 664 lbf ft
Free speed	100 r/mn (tr/mn)	100 r/mn (tr/mn)
Working pressure	3 - 7 bar	44 - 102 psi
Air consumption	19 l/s (40CFM)	19 l/s (40CFM)
Weight:		
CP7600xB	6.0 kg	13.2 lbs
CP7600xB-R	6.6 kg	14.6 lbs
CP7600xB-4P	6.3 kg	13.9 lbs
CP7600xB-R4P	6.9 kg	15.2 lbs

### Noise and vibration emission

Noise according to ISO15744	dB(A)
Measured sound pressure level	79
Determined sound power level	
Spread in method and production	3

Vibration according to ISO 8662-7	m/s <sup>2</sup>
Measured vibration value	<2.5
Spread in method and production	

### Declaration of noise and vibration emission

These declared values were obtained by laboratory type testing in accordance with the stated standards and are suitable for comparison with the declared values of other tools tested in accordance with the same standards. These declared values are not adequate for use in risk assessments and values measured in individual work places may be higher. The actual exposure values and risk of harm experienced by an individual user are unique and depend upon the way the user works, the workpiece and the workstation design, as well upon the exposure time and the physical condition of the user.

We, **CP**, cannot be held liable for the consequences of using the declared values, instead of values reflecting the actual exposure, in an individual risk assessment in a work place situation over which we have no control. This tool may cause hand-arm vibration syndrome if its use is not adequately managed. An EU guide to managing hand-arm vibration can be found at <http://www.human-vibration.com/EU/VIBGUIDE.htm> We recommend a programme of health surveillance to detect early symptoms which may relate to vibration exposure, so that management procedures can be modified to help prevent future impairment.



Part no	8940164681
Issue no	1
Series no	1
Date	2019-01
Page	4



## Copyright

© Copyright 2019, CP. All rights reserved. Any unauthorized use or copying of the contents or part thereof is prohibited. This applies in particular to trademarks, model denominations, part numbers and drawings. Use only authorized parts. Any damage or malfunction caused by the use of an authorized parts is not covered by Warranty or Product Liability.

## Principle

Inside CP7600, a valve unit combines 2 key functions: driving the air through the two pneumatic motors and shutting off the air supply of the tool.

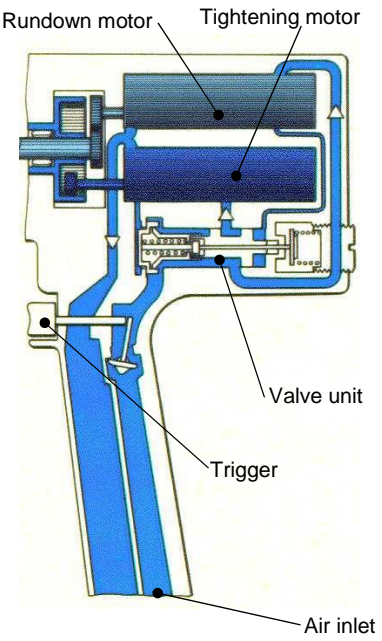

### Rundown

When pulling the trigger, the air flows through the valve unit, driving the air through the rundown motor that rotates. This motor drives a low ratio gear generating high speed and low torque.

### Motor switch

As the torque load applied on the CP7600 output drive increases, the rundown motor slows down, leading to a higher air pressure inside the motor. Under this higher pressure, the valve is pushed to another position.

### Tightening

The air is then driven through the tightening motor. This motor drives a high ratio gear generating low speed and high torque.

### Shut off

As the torque load continues to increase, the tightening motor slows down, leading to a higher air pressure in the motor. When this air pressure exceeds the adjusted pressure of a spring, a piston in the valve unit is pushed, shutting off the whole air admission.

### Adjusting the shut off

The spring pressure is adjusted when calibrating of the tool. A specific air pressure (usually 6.3 bar/90 psi) leads to a specific torque.

## WARNING



A change in the air pressure will affect the behavior of the shut off. If the air pressure is higher than the calibration air pressure, the shut off will operate earlier and the torque will be lower than expected. It is very important to run CP7600 at the air pressure written on the calibration certificate, in order to get the proper torque.

## Installation

### Air quality

- For optimum performance and maximum machine life we recommend use of compressed air with a dew point between +2°C and +10°C. Installation of a refrigeration-type air dryer is recommended.
- Use a separate air filter to remove solid particles larger than 30 microns and more than 90 % of water, installed as close as possible to the machine and prior to any other air preparation unit. Blow out the hose before connecting.
- The compressed air must contain a small quantity of oil. We strongly recommend that you install a oil-fog lubricator to be set normally at 3-4 drops(50mm<sup>3</sup>)/m<sup>3</sup> air consumption for long cycle running tools, or a single-point lubricator for short cycle running tools.
- Regarding lubrication free tools it is, at the customers option, no disadvantage if the compressed air contains a small quantity of oil as supplied from a lubricator. An exception is turbine tools that should be kept oil free. (For further information please see Air Line Accessories in our main catalogue.)

### Compressed air connection

- The machine is designed for a working pressure (e) of 3-7 bar = 300-700 kPa = 44-102 psi.
- Blow out the hose before connecting.

### Recommended installation

To ensure correct capacity of the machine, we strongly recommend you to follow the enclosed installation proposal from the air network tapping point to the tool.

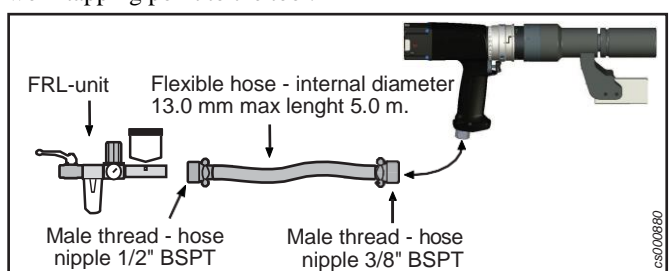

## Handling

### Tightening torque setup

For accurate operation and safety, the tightening torque of the nut runner must be set correctly in relation to the screw joint. Check the tightening torque given to the joint in question.

The air pressure supplied by the FRL unit is set according to the pressure written on the calibration certificate at free speed (trigger fully pressed and nutrunner running freely with no load during a couple of seconds) usually 6.0 - 6.3 bar = 87 - 91 psi.



### Single torque selector

Adjust the torque setting by means of the adjustment key. The torque is increased when screwing the screw counter clockwise. After adjustment, check the tightening torque given to the joint in question.

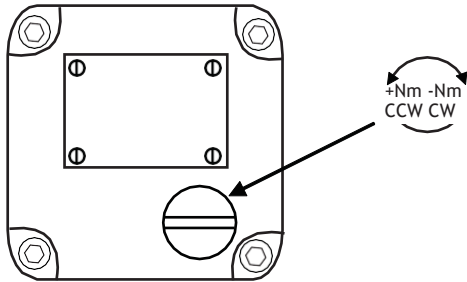

cs000850

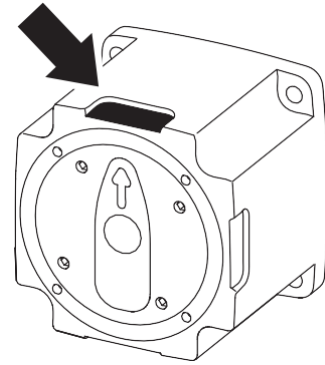

cs001050

**A** If shut-off is carried out at high speed of revolution, causing a high torque scatter, it is recommended to reduce the air pressure.

### 4-position selector

In order to set Torque 1, turn the rotary switch to the ref. mark on the housing. Set the adjustment screw 1. See mark on the switch how to increase/decrease the torque. To set Torque 2, turn the rotary switch to the Ref. 2 mark on the housing. Set the adjustment screw 2.

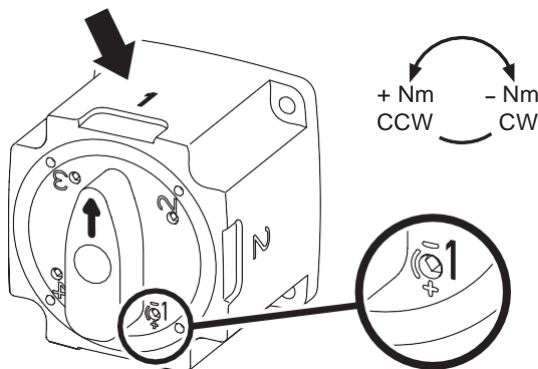

cs000800

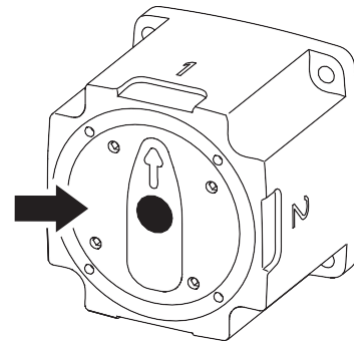

cs000810

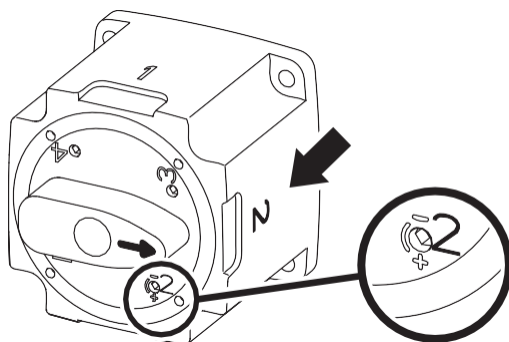

cs001040

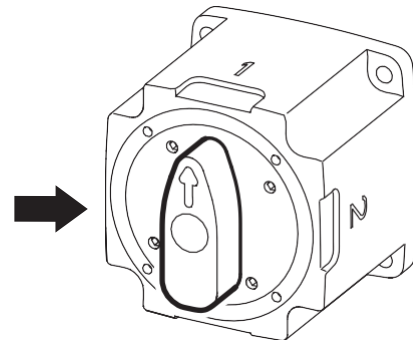

cs001060

Remember your torque settings by placing your own markings on the four areas on the housing.

### Operating instructions Tightening torque selection

Push the black button. Turn the rotary switch to desired position. Push the rotary switch back in.

**Position of the gear shift ring - clockwise gear position**

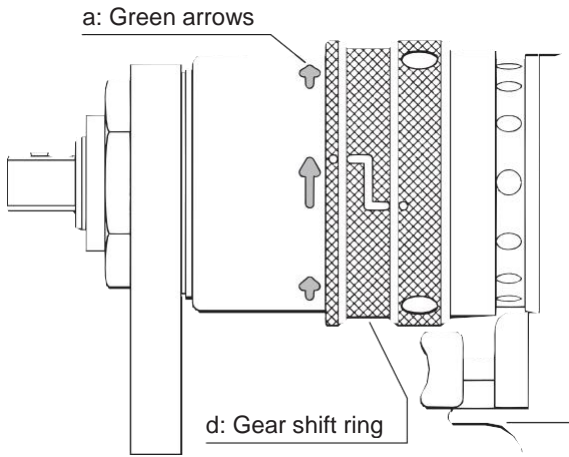

cs000940

**Position of the gear shift ring - counter-clockwise gear position**

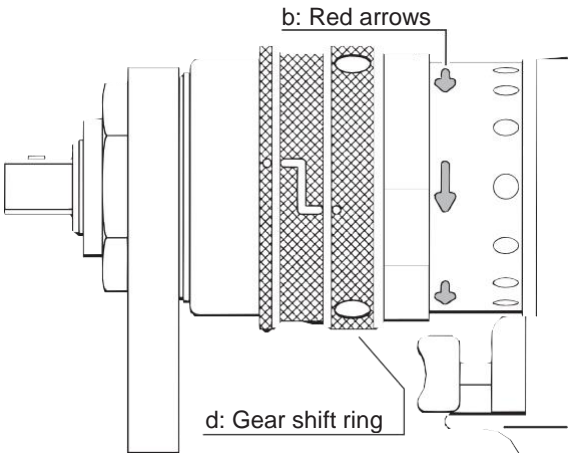

cs000950

**Position of the gear shift ring - middle gear position**

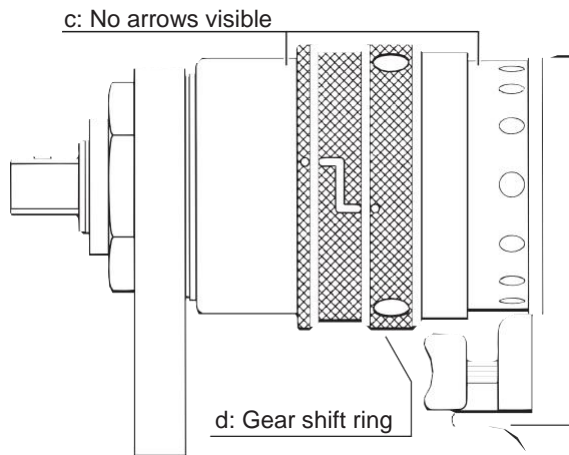

cs000960

**Instructions for reversing**

As there is no automatic return of the gear shift to a fixed position, always check before starting that gear shift is in clockwise position or counter-clockwise position with all arrows clearly visible.

**WARNING**



Never shift the gear when the machine is running. Never start the machine when gear shift is in middle position.

Grip the gear shift ring by hand and move it forward – right – forward, see Fig. below.

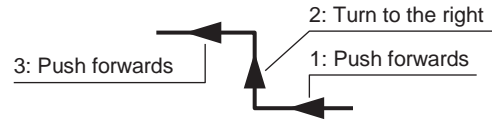

cs000970

The red arrows indicate the direction of running. I.e. the machine will run counter-clockwise when started.

When changing back to the clockwise position, pull the ring back – left – back, see Fig. below.

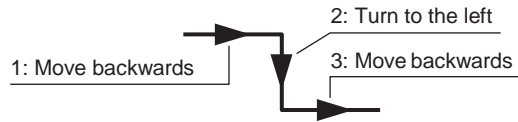

cs000980

The green arrows indicate the direction of running, i.e. the machine will run clockwise when started. It is not necessary to keep the ring in both positions by hand.

**Extended reaction arm with blade**

Check that the blade is firmly fitted into the reaction arm.

Apply the reaction bar in the wanted position - opposite the direction of the machine - before starting the machine.

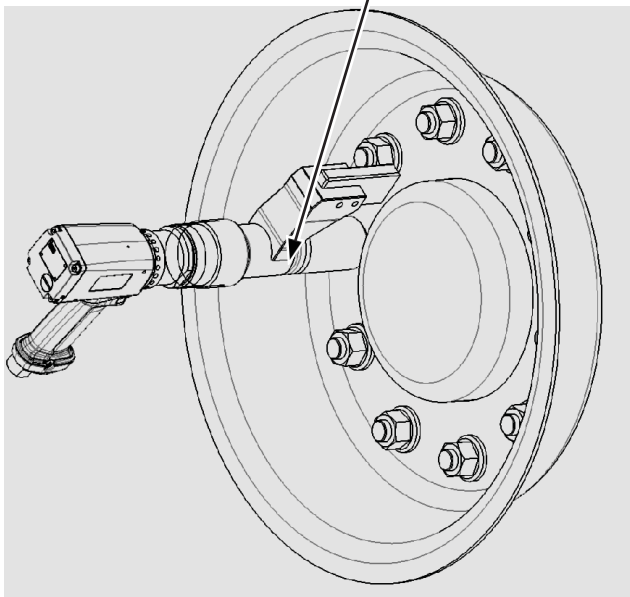
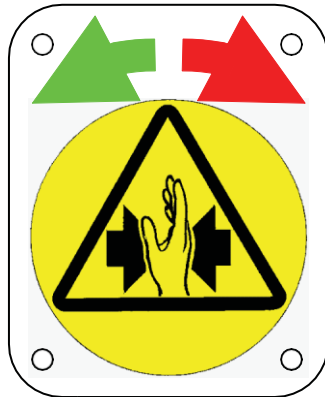

cs000860

## Maintenance

### For maximum performance

It is important to lubricate regularly to get maximum performance and trouble-free operation. The motor should be lubricated with oil; i.e. drops of oil can be dropped either into the compressed air or directly into the air inlet.

The trigger, planetary gears, needle bearings and ball bearings should be lubricated with grease during the regular overhaul of the machine.

The angle gear and clutch must be lubricated using grease that contains molybdenum disulphide: Molykote BR2 Plus, for example, or an equivalent brand.

Use lubricants of good quality. The oils and greases mentioned in the table are examples of lubricants which are recommended.

### Rust protection and internal cleaning

Water in the compressed air, dust and wear particles cause rust and sticking of vanes, valves etc. An air filter should be installed close to the machine (see "Air quality").

### Service instructions

Overhaul and preventive maintenance is recommended at regular intervals once per year or after maximum 250.000 tightening depending on which occurs sooner. More frequent overhaul may be needed, if used at high torque and long tightening times. If the

machine not is working properly, it should immediately be taken away for inspection.

The strainer at the air inlet and the exhaust silencer should be cleaned frequently or replaced in order to prevent clogging, which decreases the capacity.

At the overhauls, all parts should be cleaned accurately and defective or worn parts (i.e. O-rings, vanes) should be replaced.

### Disassembling/assembling

It is important that the machines threaded connections are tightened properly; i.e. in accordance with the specifications on the exploded views.

**A** Lubricate o-rings and threaded connections with grease before assembling.

### Cleaning

Clean all parts thoroughly in white spirit or similar cleaning agent. To prevent clogging and decreased power, it could be necessary to clean the strainer (if used) and the exhaust filter between the overhauls.

### Inspection

After the cleaning, inspect all parts. Damaged and worn parts should be replaced.

### Lubrication

Lubricate specially gears, valve and clutch with grease containing molybdenum disulphide (e.g. Molykote BR2 Plus). Please see exploded views and fig. under Service instructions.

### Grease guide Nutrunners

Brand	Bearings (general purpose)	Free wheel unit (gear rim and gear wheels)	Free wheel
BP	Energrease LS-EP2		Energrease LS-EP2
Castrol	Spheerol EPL2		
Esso	Beacon EP2		Beacon EP2
Q8	Rembrandt EP2		Rembrandt EP2
Mobil	Mobilegrease XHP 222		
Shell	Alvania EP2		Alvania EP2
Texaco	Multifak EP2		
Molycote			
Lubricating		Suntemp LE 9102	
STP		Oil treatment	

Brand	Gears	Air lubrication
Bp		Energol E46
Castro		
Esso		AroxEP46
Q8		Chopin 46
Mobil		Almo oil 525
Shell		Torcula 32
Texaco		Aries 32
Molycote	BR2 Plus	

Part no	8940164681
Issue no	1
Series no	1
Date	2019-01
Page	8



## Safety instructions

### Warning

Make sure you are familiar with the operating instructions before you use this machine.

The machine, together with any attachments and accessories, must never be used for anything other than the designated purpose.

All locally legislated safety rules with regard to installation, operation and maintenance shall be respected at all times.

Refer installation and servicing to qualified personnel only.

Before making any adjustments (e.g. changing sockets) disconnect the machine from the compressed air line.

Check the direction of the rotation before using the machine.

Operators of nutrunners with a torque reaction bar should take particular care to avoid injuries due to squeezing. For safety reasons – never allow anyone to operate the machine unless he is trained and thoroughly familiar with how the machine works in different circumstances. Refer to the section headed “Reaction bar”.

**The machine may only be used together with the associated torque reaction bar** which is adapted to the screw joint application concerned. See also the instructions under the heading “Reaction bar”.

**Never put your hand on or close to the reaction bar** while the machine is being used.

Check that the power socket is properly fastened. Replace the retaining or locking pin when necessary. Also replace any worn socket.

Keep hands, long hair or other objects away from the rotating socket.

When using a suspension yoke, check that it is in good condition and correctly fastened.



## CP Guarantee

- 1) This CP product is guaranteed against defective workmanship or materials, for a maximum period of 12 months following the date of purchase from CP or its agents, provided that its usage is limited to single shift operation throughout that period. If the usage rate exceeds that of single shift operation, the guarantee period shall be reduced on a pro rata basis.
  - 2) If, during the guarantee period, the product appears to be defective in workmanship or materials, it should be returned to CP or its agents, together with a short description of the alleged defect. CP shall, at its sole discretion, arrange to repair or replace free of charge such items as are deemed faulty by reason of defective workmanship or materials.
  - 3) This guarantee ceases to apply to products which have been abused, misused or modified, or which have been repaired using other than genuine CP spare parts or by someone other than CP or its authorized service agents.
  - 4) Should CP incur any expense correcting a defect resulting from abuse, misuse, accidental damage or unauthorized modification, they will require that such expense shall be defrayed in full.
  - 5) CP accepts no claim for labour or other expenditure made upon defective products.
  - 6) Any direct, incidental or consequential damages whatsoever arising from any defect are expressly excluded.
  - 7) This guarantee is given in lieu of all other guarantees, or conditions, expressed or implied, as to the quality, merchantability or fitness for any particular purpose.
  - 8) No one, whether an agent, servant or employee of CP, is authorized to add to or modify the terms of this limited guarantee in any way.
-

Ref. No.	Ordering No.	Qty	Description	Remark / Included in Service kit
1(2-4)	8940 1646 64	1	GEAR BOX COMPL. - R	
2	-	2	Seal ring	G32x42x4. see kit Gearbox sealing service kit - R
3	-	1	Needle bearing	B2012. see kit Gearbox rolling service kit - R
4	-	1	US extended reaction arm - R	
5	8940 1646 41	1	Blade	
6	8940 1661 80	2	Screw	M8x50
7(8-9)	8940 1671 56	1	GEAR LOCK UP - R	
8	-	4	Key	
9	-	1	RingPlan	
10(11-17)	8940 1646 56	1	PLANETARY GEAR ASSEMBLY	
11	8940 1621 93	1	Socket retaining ring	
12	8940 1621 95	1	O-ring	
13	-	1	Planet shaft	
14	-	16	washer	
15	-	128	Bearing needle	
16	-	4	Gear wheel	z=11
17	-	4	Axle	
18	-	1	Ball bearing	16006. see kit Gearbox rolling service kit - R
19(20-24)	8940 1671 69	1	PLANETARY GEAR MID	
20	-	1	Planet shaft	
21	-	8	Washer	
22	-	48	Bearing needle	
23	-	4	Gear wheel	z=16
24	-	4	Axle	
25	-	1	Ball bearing	see kit Gearbox rolling service kit - R
26	-	1	Bushing	see kit Gearbox rolling service kit - R
27(28-31)	8940 1671 57	1	GEAR RIM UP-R	
28	-	1	Lock ring	sw52
29	-	1	Pin	2x4
30	-	1	Nut	
31	-	1	Casing	
32	-	1	Gear rim	z=47
33	-	1	Pin	
34	8940 1671 61	2	Gear shift rim - R	
35	-	1	Screw	
36(37-39)	8940 1671 62	1	GEAR SHIFT RING -R	
37	-	1	Gear shift ring	
38	8940 1692 38	1	Spring	
39	8940 1692 36	1	Pin	
40(41-42)	8940 1674 08	1	PLANET SHAFT WHEEL LOW -R	
41	-	3	Needle bearing	K7x10x10TN
42	-	1	Gear wheel	z=19
43(44-47)	8940 1671 64	1	GEAR RIM LOW	
44	-	1	Washer	
45	-	1	O-ring	47.6x2.4
46	-	1	Bearing ring	see kit Free wheel unit
47	-	32	Ball bearing	
48(49-54)	8940 1671 68	1	PLANET SHAFT LOW -R	
49	-	1	Planet shaft	
50	-	2	Axle	
51	-	2	Nedle bearing	K5x8x10TN
52	-	2	Gear wheel	z=13
53	-	1	Planetary holder	
54	-	3	Axle	

Ref. No.	Ordering No.	Qty	Description	Remark / Included in Service kit
	8940 1671 58	1	GEAR RIM MID - R	
32	-	1	Gear rim	z=47
45	-	1	O-ring	47.6x2.4
	8940 1671 60	1	GEAR SHIFT DRIVE - R	
33		3	Pin	
35		3	Screw	
	8940 1671 71	1	GEARBOX SEALING SERVICE KIT - R	



Part no	8940164681	
Issue no	1	
Series no	1	
Date	2010-01	
Page	50	

Ref. No.	Ordering No.	Qty	Description	Remark / Included in Service kit
2	-	1	Seal ring	G32x42x4
45	-	1	O-ring	47.6x2.4
	8940 1671 72	1	GEARBOX ROLLING SERVICE KIT	
3	-	1	Needle bearing	B2012
18	-	1	Ball bearing	16006
25	-	1	Ball bearing	
26	-	1	Bushing	

**Free wheel unit -R**

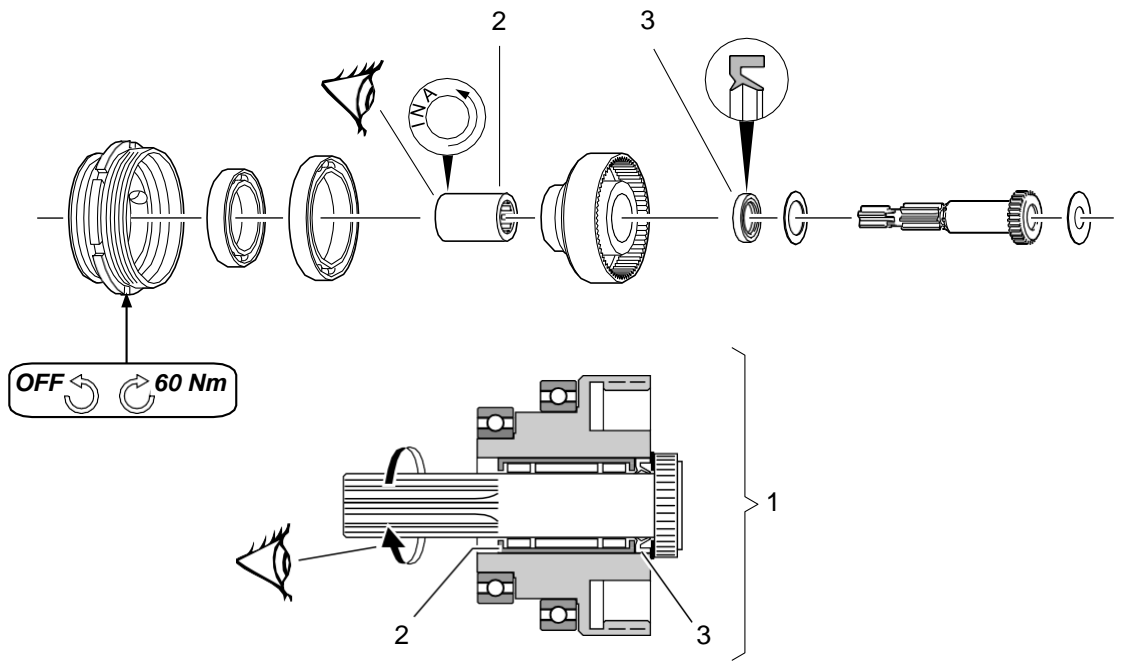

Ref. No.	Ordering No.	Qty	Description	Remark / Included in Service kit
1(2-3)	8940 1658 56	1	Complete free wheel unit -R	Included in 8940 1646 58
2	-	1	Free wheel	FCB-12 / Service kit 8940 1658 50
3	-	1	Seal ring	SD12x8x3 / Service kit 8940 1658 50

c000710



**Gear unit - no R**

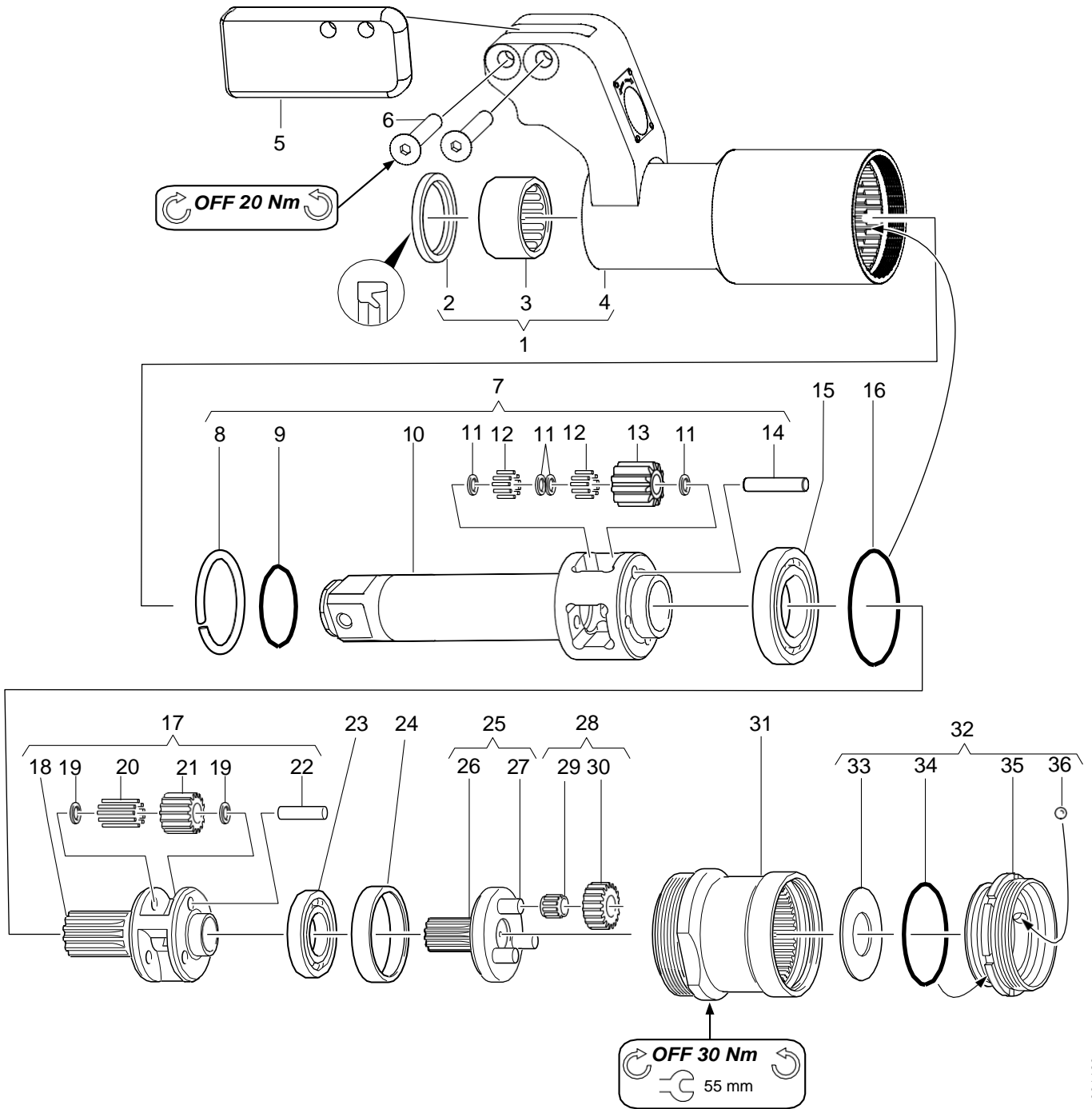

c001160

Ref. No.	Ordering No.	Qty	Description	Remark / Included in Service kit
1(2-4)	8940 1646 54	1	GEAR BOX COMPLETE - NO R	
2	-	1	Seal ring	G32x42x4. see kit Gearbox sealing service kit -no R
3	-	1	Needle bearing	B2012. see kit Gearbox rolling service kit
4	-	1	US extended reaction arm-noR	
5	8940 1646 41	1	Blade	
6	8940 1661 80	2	Screw	M8x50



7(8-14)	8940 1646 56	1	PLANETARY GEAR ASSEMBLY
8	8940 1621 93	1	Socket retaining ring
9	8940 1621 95	1	O-ring
10	-	1	Planet shaft
11	-	16	Washer



Part no	8940164681	
Issue no	1	
Series no	1	
Date	2010-01	
Page	52	

Ref. No.	Ordering No.	Qty	Description	Remark / Included in Service kit
12	-	128	Bearing needle	
13	-	4	Gear wheel	z=11
14	-	4	Axle	
15	-	1	Ball bearing	16006. see kit Gearbox rolling service kit
16	-	1	O-ring	54x2.5. see kit Gearbox sealing service kit -no R
17(18-22)	8940 1671 69	1	PLANETARY GEAR MID	
18	-	1	Planet shaft	
19	-	6	Washer	
20	-	48	Bearing needle	
21	-	3	Gear wheel	z=16
22	-	3	Axle	
23	-	2	Ball bearing	see kit Gearbox rolling service kit
24	-	2	Bushing	see kit Gearbox rolling service kit
25(26-27)	8940 1671 67	1	PLANET SHAFT LOW -NO R	
26	-	1	KeyKe	z=13
27	-	3	Axle	
28(29-30)	8940 1671 63	1	PLANET SHAFT WEEL LOW - NO R	
29	-	3	Needle bearing	K710x10TN
30	-	1	Gear wheel	z=19
31	-	1	Gear rim	z=47
32(33-36)	8940 1671 64	1	GEAR RIM LOW	
33	-	1	Washer	
34	-	2	O-ring	47.6x2.4. see kit Gearbox sealing service kit -no R
35	-	1	Bearing ring	
36	-	32	Ball bearing	5mm

Ref. No.	Ordering No.	Qty	Description	Remark / Included in Service kit
	8940 1671 59	1	GEAR RIM MID -NOR	
16	-	1	O-ring	54x2.5
31	-	1	Gear rim	z=47
34	-	1	O-ring	47.6x2.4
	8940 1671 70	1	GEARBOX SEALING SER- VICE KIT - NO R	
2	-	1	Seal ring	G32x42x4
16	-	1	O-ring	54x2.5
34	-	1	O-ring	47.6x2.4
	8940 1671 72	1	GEARBOX ROLLING SER- VICE KIT	
3	-	1	Needle bearing	B2012
15	-	1	Ball bearing	16006
23	-	1	Ball bearing	
24	-	1	Bushing	



### Free wheel unit - no R

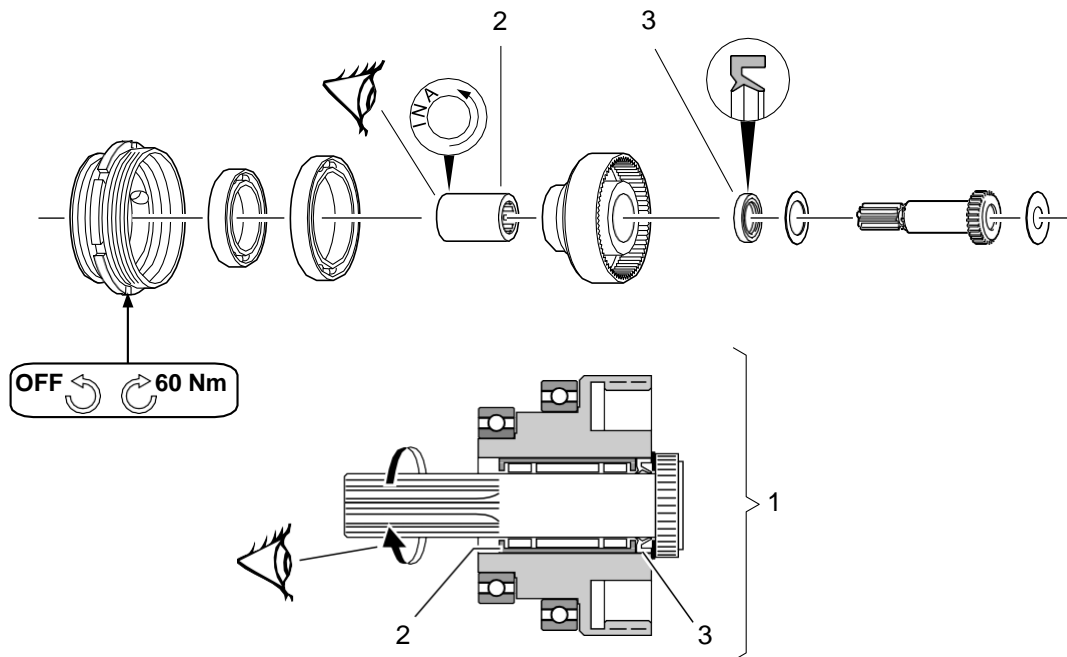

Ref. No.	Ordering No.	Qty	Description	Remark / Included in Service kit
1(2-3)	8940 1658 57	1	Complete free wheel unit - noR	
2	-	1	Free wheel	FCB-12 / Service kit 8940 1658 50
3	-	1	Seal ring	SD12x8x3 / Service kit 8940 1658 50

### Tightening motor

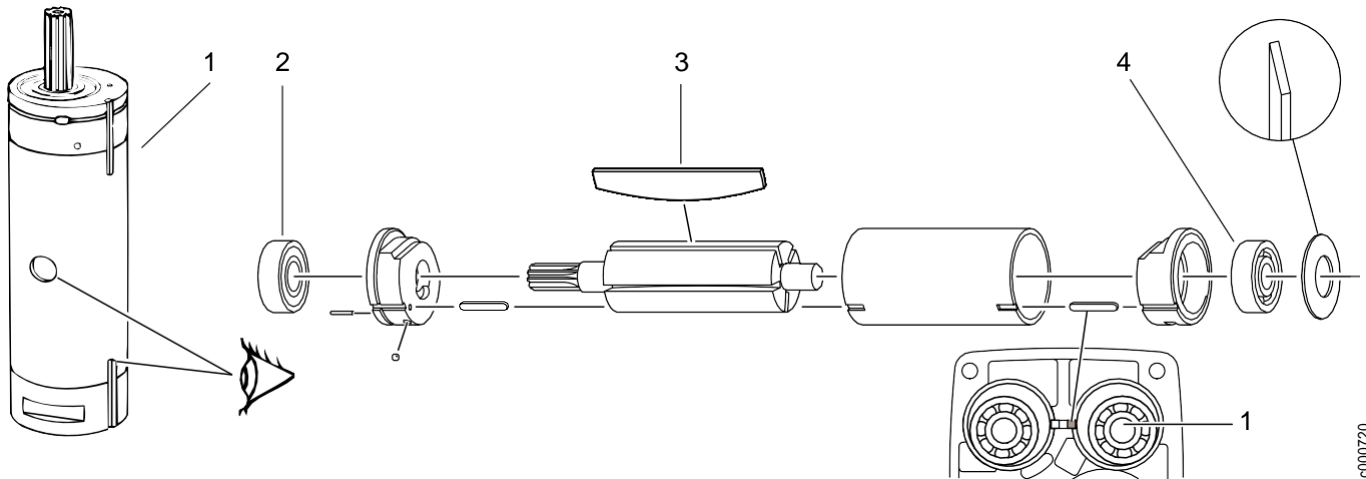

Ref. No.	Ordering No.	Qty	Description	Remark / Included in Service kit
1(2-4)	8940 1658 58	1	Tightening motor, complete	
2	-	1	Ball bearing	698Z
3	-	5	Vane	Service kit 8940 1658 50
4	-	1	Ball bearing	607 / Service kit 8940 1658 50

### Run down motor

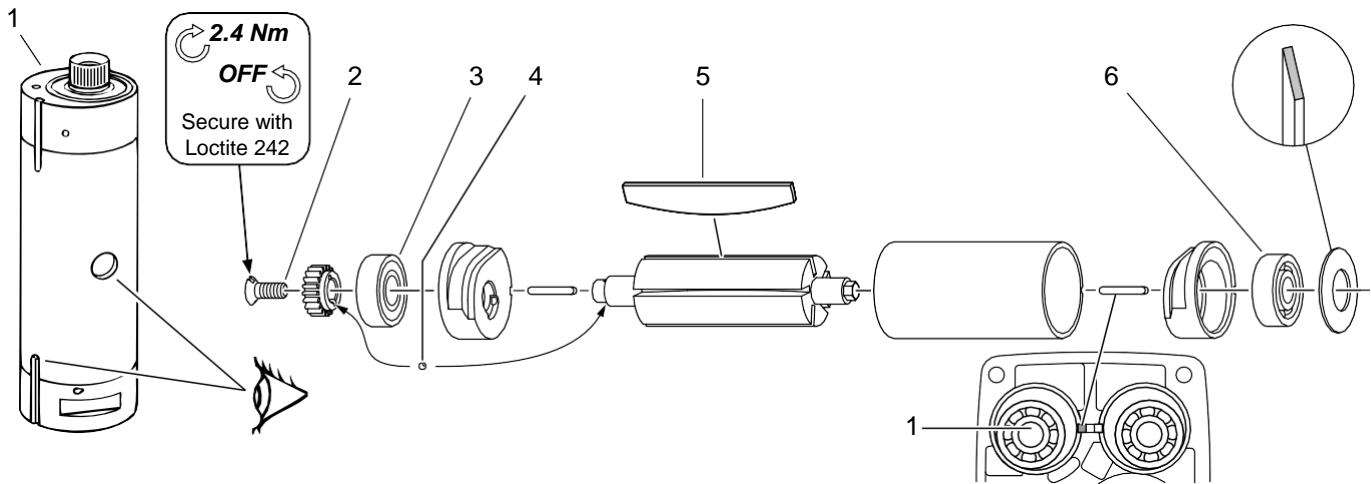

c000730

Ref. No.	Ordering No.	Qty	Description	Remark / Included in Service kit
1(2-6)	8940 1658 59	1	Run down motor compl.	
2	-	1	Screw	MFS 4x10 / Service kit 8940 1658 50
3	-	1	Ball bearing	698Z / Service kit 8940 1658 50
4	-	1	Ball	1.5mm / Service kit 8940 1658 50
5	-	5	Vane	Service kit 8940 1658 50
6	-	1	Ball bearing	607 / Service kit 8940 1658 50

### Valve unit

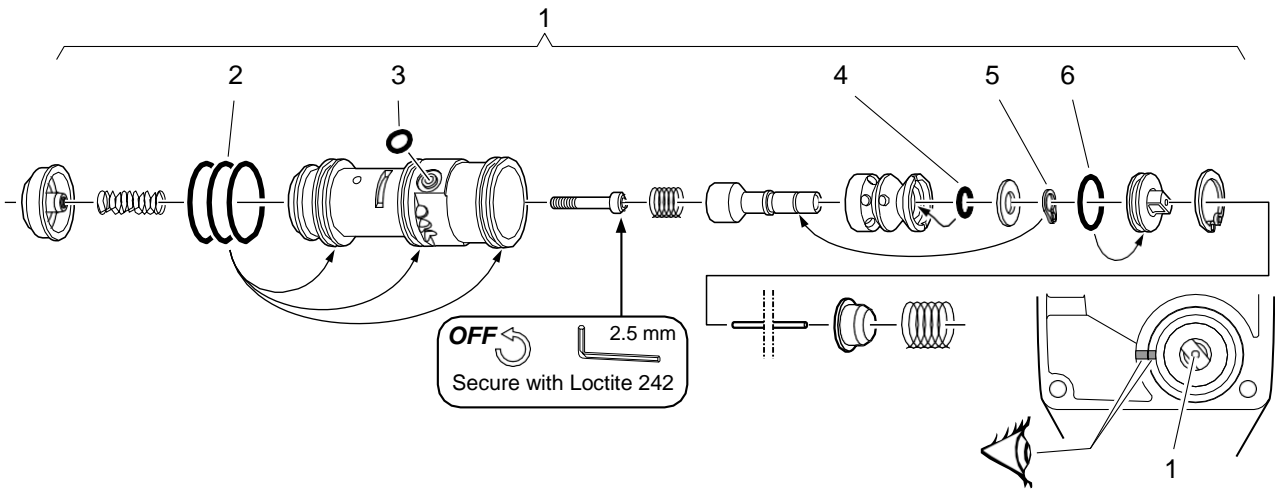

c000740

Ref. No.	Ordering No.	Qty	Description	Remark / Included in Service kit
1(2-6)	8940 1658 53	1	Valve unit compl.	
2	-	3	O-ring	19.1x1.6 / Service kit 8940 1658 50
3	-	1	O-ring	4.1x1.6 / Service kit 8940 1658 50
4	-	1	O-ring	5.28x1.78 / Service kit 8940 1658 50
5	-	1	Circlip	
6	-	1	O-ring	12.1x1.6 / Service kit 8940 1658 50

### Trigger valve

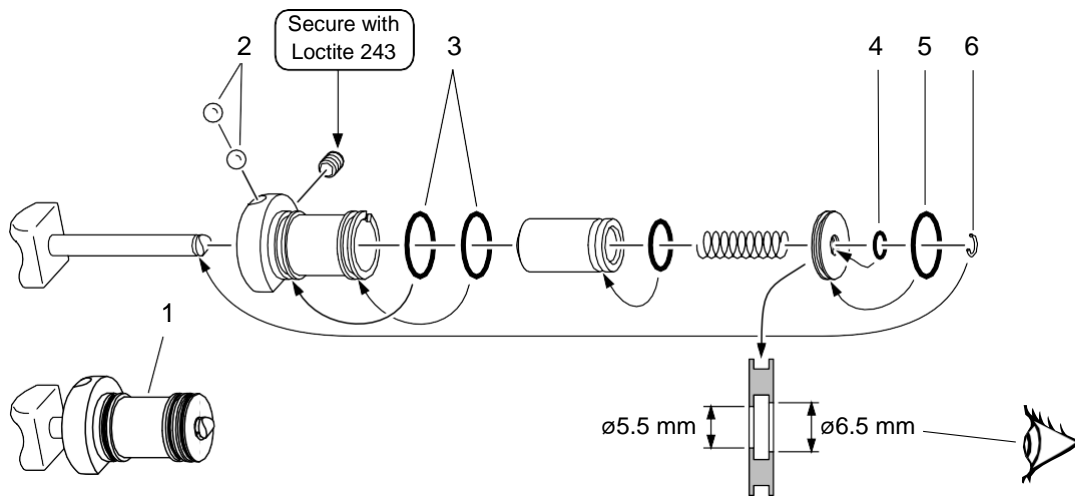

Ref. No.	Ordering No.	Qty	Description	Remark / Included in Service kit
1(2-6)	8940 1658 54	1	Trigger valve compl.	
2	-	2	Ball	Service kit 8940 1658 50
3	-	2	O-ring	19.1x1.6 / Service kit 8940 1658 50
4	-	1	O-ring	5.1x1.6 / Service kit 8940 1658 50
5	-	1	O-ring	15.1x1.6 / Service kit 8940 1658 50
6	-	1	Lock ring	Service kit 8940 1658 50

c000750

Part no	8940164681
Issue no	1
Series no	1
Date	2010-01
Page	56

### Motor casing

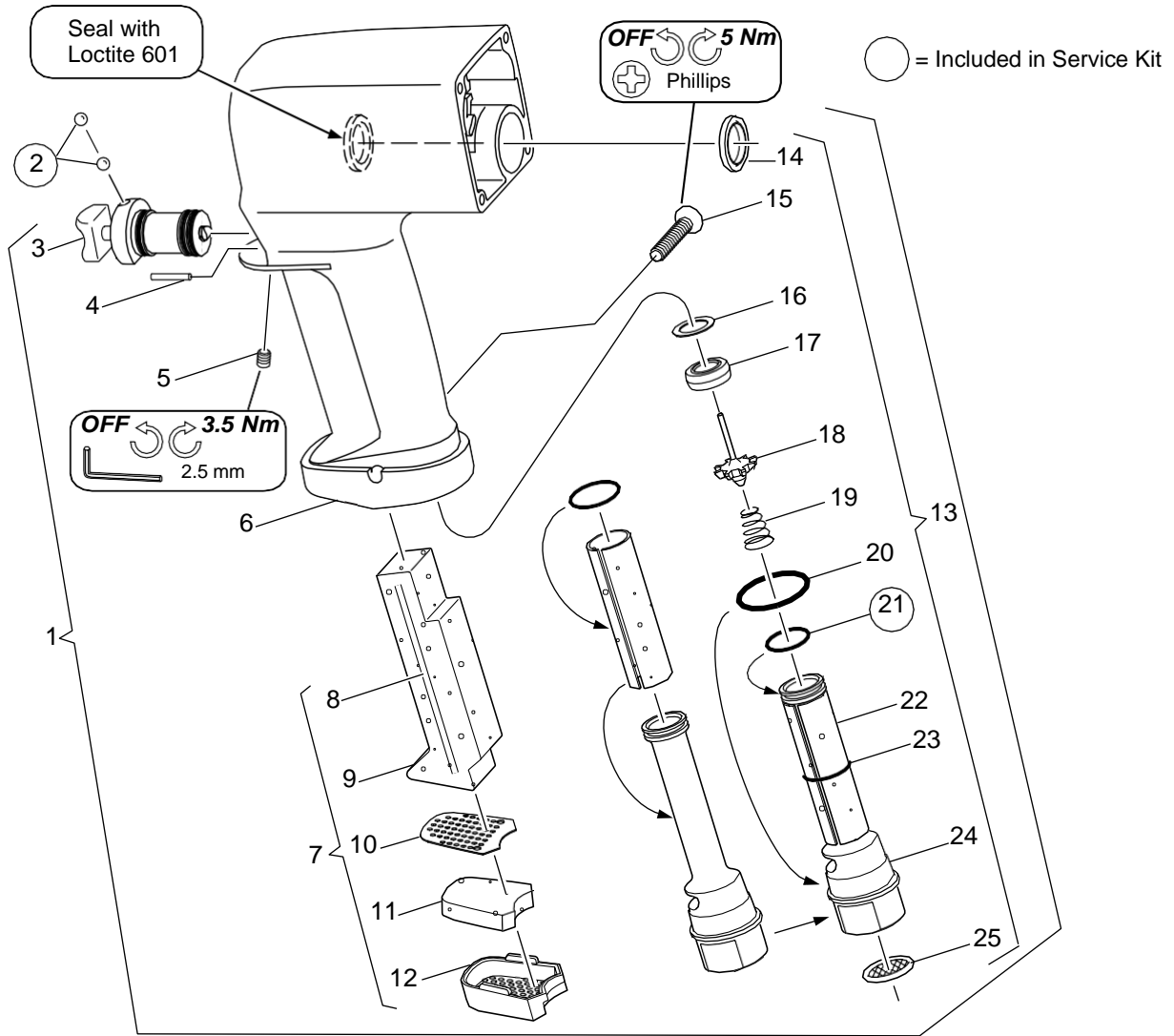

Ref. No.	Ordering No.	Qty	Description	Remark / Included in Service kit
1(3-25)	8940 1658 55	1	Motor casing	
3	8940 1658 54	1	Trigger valve, compl.	
4	-	1	Pin	
5	-	1	Screw	P6SS 5x6
6	-	1	Handle, compl.	
7(8-12)	8940 1671 65	1	Exhaust, compl.	
8	-	1	Filter	
9	-	1	Yoke	
10	-	1	Plate	
11	-	1	Filter	
12	-	1	Silencer	
13(14-25)	8940 1671 66	1	Inlet pipe, compl.	
14	-	1	Seat	
15	-	1	Screw	M6x35
16	-	1	Washer	
17	8940 1692 37	1	Seat	
18	-	1	Walve	
19	-	1	Spring	
20	-	1	O-ring	26.2x2.5
21	-	1	O-ring	15.1x1.6
22	-	1	Filter	
23	-	1	O-ring	12.1x1.6
24	-	1	Inlet pipe	
25	-	1	Strainer	
2	-	2	Ball	5mm / Service kit 8940 1658 50

c000760



	Part no	8940164681
	Issue no	1
	Series no	1
	Date	2010-01
	Page	57

### Motor cover

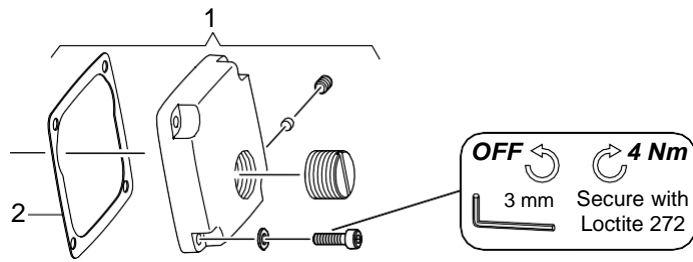

c000780

Ref. No.	Ordering No.	Qty	Description	Remark / Included in Service kit
1	8940 1658 52	1	Motor cover, compl.	CP7600/CP7600-R
2		1	Gasket	Service kit 8940 1658 50

### 4-position selector

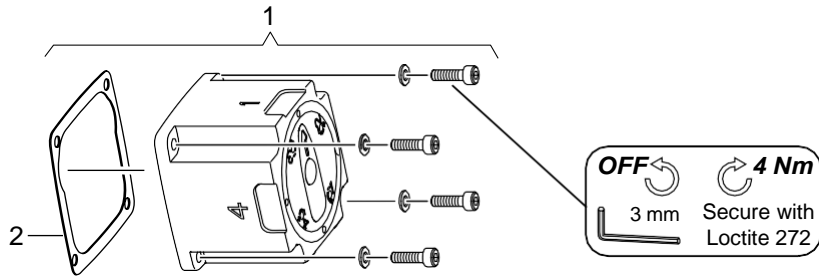

c000770

Ref. No.	Ordering No.	Qty	Description	Remark / Included in Service kit
1	8940 1658 51	1	4-position selector, compl.	CP7600-4P/CP7600-R4P
2		1	Gasket	Service kit 8940 1658 50

### Included accessories

#### Protective covers

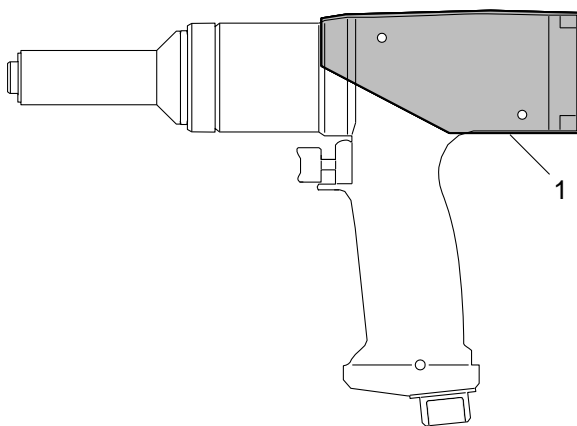

c000790

Ref. No.	Ordering No.	Qty	Description	Remark / Included in Service kit
1	8940 1646 48	1	Black protective cover	for CP7600 with motor cover
1	8940 1646 49	1	Blue protective cover	for CP7600 with motor cover
1	8940 1646 50	1	Black protective cover	for CP7600 with 4-position selector
1	8940 1646 51	1	Blue protective cover	for CP7600 with 4-position selector



Part no	8940164681
Issue no	1
Series no	1
Date	2010-01
Page	58

### Blade protective cover

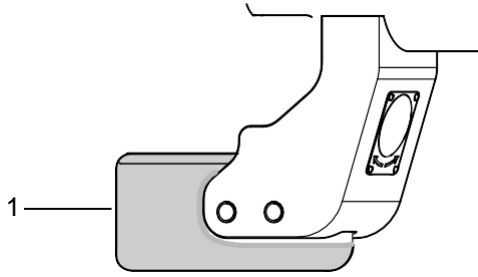

c001130

Ref. No.	Ordering No.	Qty	Description	Remark / Included in Service kit
1	8940 1672 61	1	Blade protective cover	3mm thick PVC

### Optional accessories

#### Suspension yoke

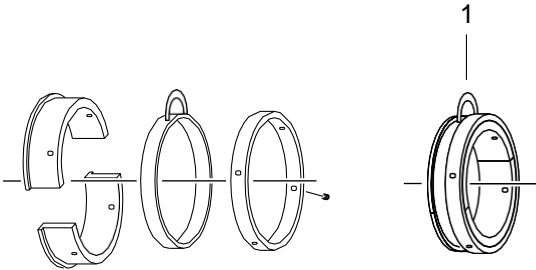

c000630

Ref. No.	Ordering No.	Qty	Description	Remark / Included in Service kit
1	8940 1666 54	1	Suspension yoke	for CP7600 reverse
1	8940 1666 59	1	Suspension yoke	for CP7600 none reverse

#### Power sockets

Ref. No.	Ordering No.	Qty	Description	Remark / Included in Service kit
1	8940 1646 76	1	1" Surface drive 30 metric	Square drive
1	8940 1646 77	1	1" Surface drive 32 metric	Square drive
1	8940 1646 78	1	1" Surface drive 33 metric	Square drive
1	8940 1646 79	1	1" Thin wall socket 32 metric	Square drive deep
1	8940 1646 80	1	1" Thin wall socket 33 metric	Square drive deep

#### Flexible hose kit

Ref. No.	Ordering No.	Qty	Description	Remark / Included in Service kit
1	8940 1667 45	1	Flexible hose kit 1/2" male to length = 1.20 m	3/8" male



## Service Kits

### Service Kit

Ordering No. 8940 1658 50

Ordering No.	Qty	Description	Remark / Included in Service kit
-	1	Screw	
-	1	Circlip	SgA 5
-	2	Ball bearing	607
-	2	Ball bearing	698 Z
-	1	Ball	1.5mm
-	5	Ball	5mm
-	1	O-ring	4.1x1.6
-	1	O-ring	5.1x1.6
-	2	O-ring	11.1x1.6
-	1	O-ring	12.1x1.6
-	4	O-ring	15.1x1.6
-	3	O-ring	19.1x1.6
-	1	O-ring	5.28x1.78
-	1	Seal ring	
-	1	Free wheel	
-	10	Vane	
-	1	Bushing	
-	1	Lock ring	
-	1	Gasket	

Kit for a variety of products. Some parts might remain unused.

### Lubrication for pneumatic tools

Ordering No.	Qty	Description	Remark
CA00 0046	1	Protecto-Lube oil SAE #10	591 cc (20 oz)
CA14 9661	1	Protecto-Lube oil SAE #10	118 cc (4 oz)



## Dismantling/inspection/assembly

### Instructions for vane motor

#### Dismantling

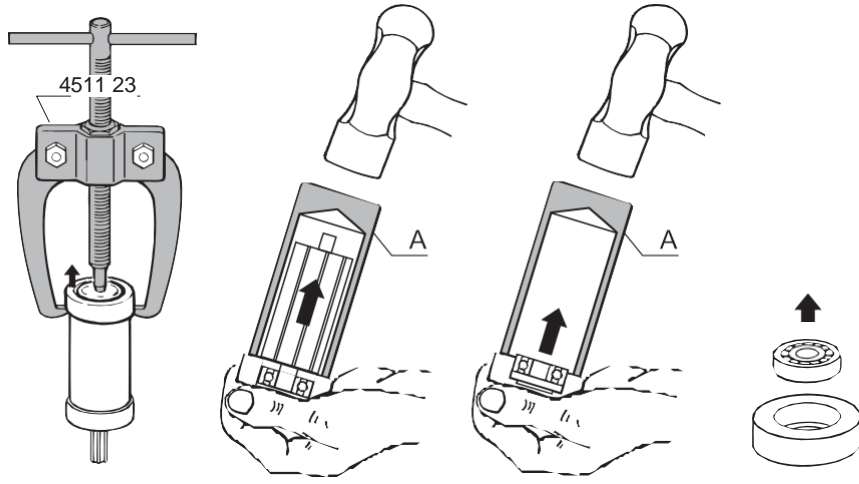

#### Dismantling tool Mandrel A

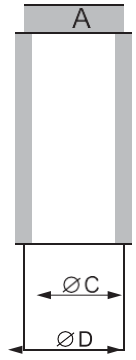

Ordering No.	$\varnothing D$	$\varnothing C$
4509 73	26	20.5
4509 83	30	25.5
4509 93	35	30.5
4510 13	40	35.5
4510 33	47	40.5

#### Inspection and lubrication

(R) = To be replaced at every overhaul  
(included in Service Kit)

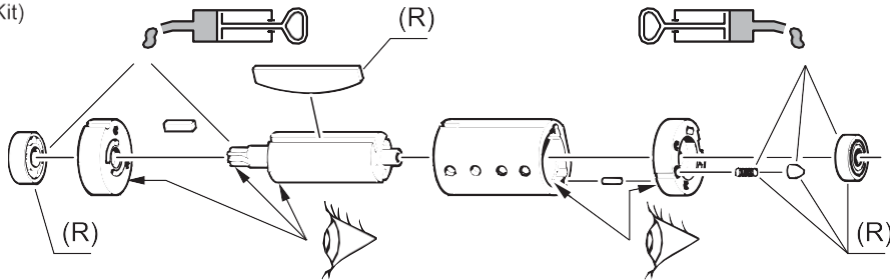

#### Assembly

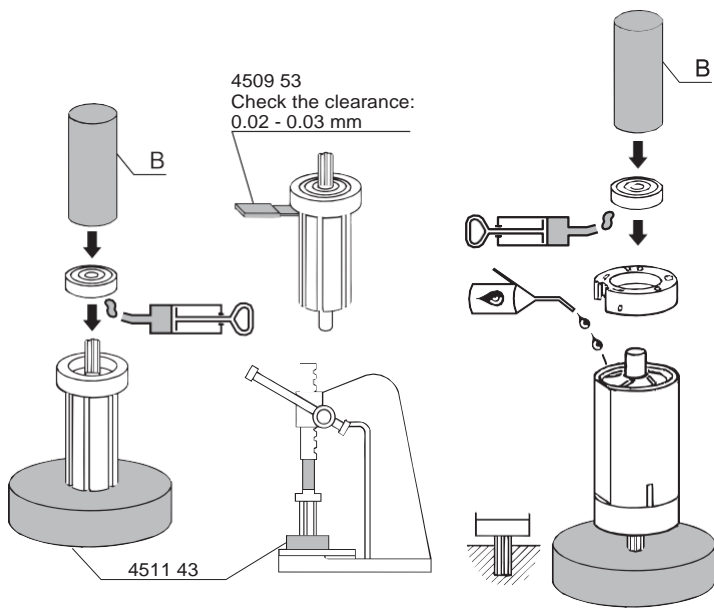

#### Assembly tool Mandrel B

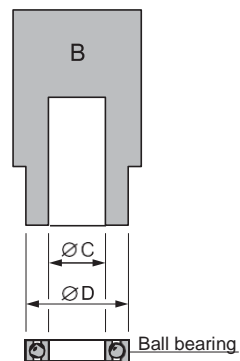

Ordering No.	$\varnothing D$	$\varnothing C$
4511 63	15.5	5.2
4540 43	18.5	8.2
4540 43	18.5	8.2
2050 5145 33	21.5	7.2
4595 93	25.5	10.5
4596 03	27.5	12.5
4596 03	27.5	12.5
4596 13	31.5	15.5
4596 13	31.5	15.5
2050 5145 13	34.5	18.5

cs001070





CP Chicago Pneumatic  
ZAC de la lorie - 38  
rue Bobby Sands 44800 Saint Herblain, France  
www.cp.com

Part no	8940164681
Issue no	1
Series no	1
Date	2010-01
Page	65

8941076010, 8941076011, 8941076014, 8941076015