

Item	Tightening torque
35	30 N.m / 21 ft.lbs
12	5 N.m / 3.7 ft.lbs
23	40 N.m / 29 ft.lbs
41 / 15	10 N.m / 7.3 ft.lbs
45 / 48	Finger-tight

	8950900063	Warning Label
	6159923670	Operator's manual
	6159948760	Safety Instructions

Item	CP Part No.	Description	Q'ty
A	6153951310	Air inlet kit	
1		Inlet with screen	1
2		O-ring	1
B	6153101200	Throttle handle ass'y	
3	6156812220	Spring	1
5	6151431930	Valve seat	1
7		Throttle handle	1
8		Valve bushing	1
9		O-ring	1
12	6156102780	Screw (set of 4) (Hex Key 4 mm)	2
C	8940173447	Safety lever kit	
10		Spring pin	1
11		Lever ass'y	1
D	6153900710	Side handle ass'y	
12	6156102780	Screw (set of 4) (Hex Key 4 mm)	2
13		Side handle	1
14	6156701620	Handle plug	1
E	6155657630	Motor cover kit	
15	6156102800	Screw (set of 4) (5mm hex key)	1
16		Cover	1
17		Ball seat	1
18		Gasket	1
19		Rubber seal	1
F	6155657650	Motor housing kit	
20		Motor housing	1
21		O-ring	1
22		Oil seal	1
G	6155042320	6" guard top kit (CP3340 SALAVET only)	
36		Guard 6"	1
41	6156102790	Screw (set of 4) (5mm hex key)	1
H	6155042330	6" guard bottom kit (CP3340 SALAVET only)	
37		Protector 6"	1
38		Bolts (set of 4)	1
39		Washer (set of 4)	1
40		Nut (set of 4)	1
I	6155042340	7" guard kit (CP3340 SALAVAD)	
41	6156102790	Screw (set of 4) (5mm hex key)	1
42		Guard 7"	1

Item	CP Part No.	Description	Q'ty
J	6155042350	9" guard kit (CP3340 SALAVEL)	
41	6156102790	Screw (set of 4) (5mm hex key)	1
43		Guard 9"	1
K	6155483070	Type 6 and 11 wheel retention kit (CP3340 SALAVET)	
44		Cover	1
45	6156102750	Safety screw (Hex key - 5/32")	1
L	6155483080	Type 27 and 42 wheel retention kit (CP3340 SALAVAD & CP3340 SALAVEL)	
46		Hub (Spanner - 24 mm)	1
47		Front flange (Pin wrench 32mm / Ø3)	1
48	6156102750	Safety screw (Hex key - 5/32")	1
M	6153994130	Tune Up Kit (included : 2, 9 18, 19, 21, 22, 31 & 54)	

4	6151431830	Ball valve	1
6	6151431850	Valve stem	1
23	6156701750	Nut (Spanner - 51mm)	1
24	6156401230	Wave washer	1
25	8940167993	Front bearing	1
26	6154201780	Front end plate	1
27	6154001790	Cylinder (incl. 28)	1
29	6154321060	Spacer	1
30	6154270090	Rotor (Hex key - 5/16")	1
31	6154340740	Blades (set of 4)	1
32	6156701720	Rotor plug (set of 5)	1
33	6154201770	Rear end plate	1
34	6157530990	Rear bearing	1
35	6154570690	Governor ass'y 6000RPM (CP3330 SALAVET & CP3330 SALAVEL)	1
	6154570730	Governor ass'y 8500RPM (CP3330 SALAVAD)	1
49	6158020720	Spanner - 51mm (for item 23)	1
50	6158020730	Hex key - 5/16" (for item 30)	1
51	6158020740	Hex key - 5/32" (for item 48 & 45)	1
52	8950290147	Pin wrench 32mm / Ø3 (for item 47)	1
53	6158020750	Spanner - 24 mm (for item 46)	1
54		O-ring	1
Not shown	2050500263	Hex key - 4 mm (for item 12)	1
Not shown	8951011470	Hex key - 5 mm (for item 15 & 41)	1

Spare parts without part number are not sold separately
Contact us at www.cp.com

Reinstating the overspeed shut-off device

- Push the ball out of the seat from the bottom to retrieve it from the cover.

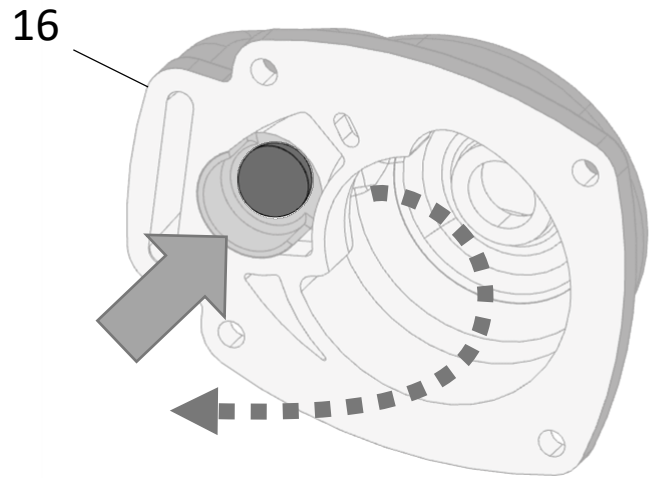

- Push the ball into the governor (in the space between the cage and the disc).
The ball should seat in the hole of the disc (X on the picture).

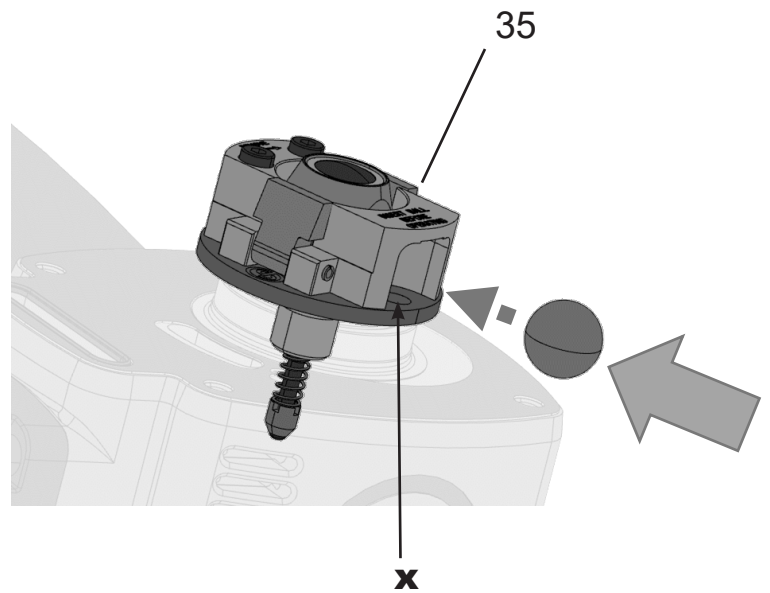

**The tool shall never be started without the ball locked in the disc groove.
The tool shall never be started without the proper governor (35) fastened to the rotor (30).**