

Item	Tightening torque
35	30 N.m / 21 ft.lbs
12	5 N.m / 3.7 ft.lbs
23	40 N.m / 29 ft.lbs
41 / 15	10 N.m / 7.3 ft.lbs
45 / 48	Finger-tight

	8950900063	Warning Label
	6159923670	Operator's manual
	6159948760	Safety Instructions

Item	CP Part No.	Description	Q'ty
<b>A</b>	<b>6153951310</b>	<b>Air inlet kit</b>	
1		Inlet with screen	1
2		O-ring	1
<b>B</b>	<b>6153101200</b>	<b>Throttle handle ass'y</b>	
3	6156812220	Spring	1
5	6151431930	Valve seat	1
7		Throttle handle	1
8		Valve bushing	1
9		O-ring	1
12	6156102780	Screw (set of 4) (4 mm Hex Key)	2
<b>C</b>	<b>8940173447</b>	<b>Safety lever kit</b>	
10		Spring pin	1
11		Lever ass'y	1
<b>D</b>	<b>6153900710</b>	<b>Side handle ass'y</b>	
12	6156102780	Screw (set of 4) (4 mm Hex Key)	2
13		Side handle	1
14	6156701620	Handle plug	1
<b>E</b>	<b>6155657630</b>	<b>Motor cover kit</b>	
15	6156102800	Screw (set of 4) (5mm hex key)	1
16		Cover	1
17		Ball seat	1
18		Gasket	1
19		Rubber seal	1
<b>F</b>	<b>6155657640</b>	<b>Motor housing kit</b>	
20		Motor housing	1
21		O-ring	1
22		Oil seal	1
<b>G</b>	<b>6155042320</b>	<b>6" guard top kit (CP3330 SALAVET only)</b>	
36		Guard 6"	1
41	6156102790	Screw (set of 4) (5mm hex key)	1
<b>H</b>	<b>6155042330</b>	<b>6" guard bottom kit (CP3330 SALAVET only)</b>	
37		Protector 6"	1
38		Bolts (set of 4)	1
39		Washer (set of 4)	1
40		Nut (set of 4)	1
<b>I</b>	<b>6155042340</b>	<b>7" guard kit (CP3330 SALAVAD only)</b>	
41	6156102790	Screw (set of 4) (5mm hex key)	1
42		Guard 7"	1

Item	CP Part No.	Description	Q'ty
<b>J</b>	<b>6155042350</b>	<b>9" guard kit (CP3330 SALAVEL only)</b>	
41	6156102790	Screw (set of 4) (5mm Hex Key)	1
43		Guard 9"	1
<b>K</b>	<b>6155483070</b>	<b>Type 6 and 11 wheel retention kit (CP3330 SALAVET only)</b>	
44		Cover	1
45	6156102750	Safety screw (5/32" Hex Key)	1
<b>L</b>	<b>6155483080</b>	<b>Type 27 and 42 wheel retention kit ( CP3330 SALAVAD &amp; CP3330 SALAVEL)</b>	
46		Hub (Spanner - 24 mm)	1
47		Front flange (Pin wrench 32mm / Ø3)	1
48	6156102750	Safety screw (5/32" Hex Key)	1
<b>M</b>	<b>6153994120</b>	<b>Tune Up Kit (included : 2, 9 18, 19, 21, 22, 31 &amp; 54)</b>	

4	6151431830	Ball valve	1
6	6151431850	Valve stem	1
23	6156701750	Nut (Spanner - 51mm)	1
24	6156401230	Wave washer	1
25	8940167993	Front bearing	1
26	6154201760	Front end plate	1
27	6154001780	Cylinder (incl. #28)	1
29	6154321060	Spacer	1
30	6154270080	Rotor (Hex key - 5/16")	1
31	6154340730	Blade (set of 5)	1
32	6156701720	Rotor plug (set of 5)	1
33	6154201750	Rear end plate	1
34	6157530990	Rear bearing	1
35	6154570690	Governor ass'y 6000RPM (CP3330 SALAVET & CP3330 SALAVEL)	1
	6154570730	Governor ass'y 8500RPM (CP3330 SALAVAD)	1
49	6158020720	Spanner - 51mm (for item 23)	1
50	6158020730	Hex key - 5/16" (for item 30)	1
51	6158020740	Hex key - 5/32" (for item 48 & 45)	1
52	8950290147	Pin wrench 32mm / Ø3 (for item 47)	1
53	6158020750	Spanner - 24 mm (for item 46)	1
54		O-ring	1
Not shown	2050500263	Hex key - 4 mm (for item 12)	1
Not shown	8951011470	Hex key - 5 mm (for item 15 & 41)	1

## Reinstating the overspeed shut-off device

- Push the ball out of the seat from the bottom to retrieve it from the cover.

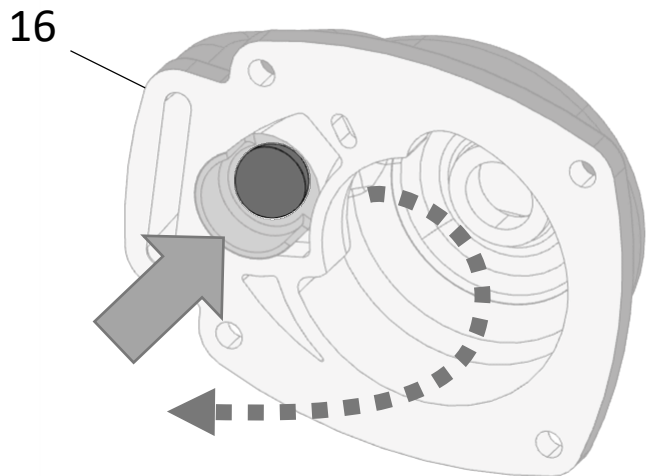

- Push the ball into the governor (in the space between the cage and the disc).  
The ball should seat in the hole of the disc (X on the picture).

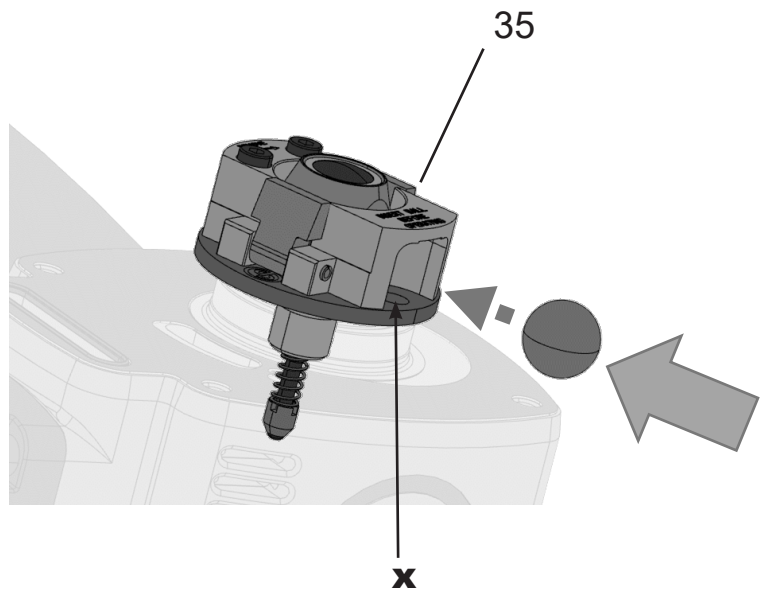

**The tool shall never be started without the ball locked in the disc groove.  
The tool shall never be started without the proper governor (35) fastened to the rotor (30).**