

Important Operating, Maintenance and Safety Instructions

Carefully read all instructions before operating or servicing any Dynabrade® Abrasive Power Tool.

Warning: Hand, wrist and arm injury may result from repetitive work motion and overexposure to vibration.

Important: All Dynabrade air tools must be used with a Filter-Regulator-Lubricator to maintain all warranties.

Operating Instructions:

Warning: Eye, face and body protection must be worn while operating power tools. Failure to do so may result in serious injury or death. Follow safety procedures posted in workplace.

1. With power source disconnected from tool, securely fasten abrasive/accessory on tool.
2. Install air fitting into inlet bushing of tool. **Important:** Secure inlet bushing of tool with a wrench before attempting to install the air fitting to avoid damaging valve body housing.
3. Connect power source to tool. Be careful not to depress throttle lever in the process.
4. Check tool speed with tachometer. If tool is operating at a higher speed than the RPM marked on the tool or operating improperly, the tool should be serviced to correct the cause before use.

Maintenance Instructions:

1. Check tool speed regularly with a tachometer. If tool is operating at a higher speed than the RPM marked on the tool, the tool should be serviced to correct the cause before use.
2. Some silencers on air tools may clog with use. Clean and replace as required.
3. All Dynabrade air motors should be lubricated. Dynabrade recommends one drop of air lube per minute for each 10 SCFM (example : if the tool specification state 40 SCFM, set the drip rate of your filter-lubricator at 4 drops per minute). Dynabrade Air Lube (P/N 95842: 1pt. 473ml.) is recommended.
4. An air line filter-regulator-lubricator must be used with this air tool to maintain all warranties. Dynabrade recommends the following: **11299** Air Line Filter-Regulator-Lubricator — Provides accurate air pressure regulation, two-stage filtration of water contaminants and micro-mist lubrication of pneumatic components. Operates 100 CFM @ 100 PSI has 1/2" NPT female ports.
5. Use only genuine Dynabrade replacement parts. To reorder replacement parts, specify the **Model #**, **Serial #**, and **RPM** of your machine.
6. A motor tune-up kit (P/N 96259) is available which includes assorted parts to help maintain motor in peak operating condition.
7. Mineral spirits are recommended when cleaning the tool and parts. Do not clean tool or parts with any solvents or oils containing acids, esters, keytones, chlorinated hydrocarbons or nitro carbons.

Safety Instructions:

Products offered by Dynabrade should not be converted or otherwise altered from original design without expressed written consent from Dynabrade, Inc.

- **Important:** User of tool is responsible for following accepted safety codes such as those published by the American National Standards Institute (ANSI).
- Operate machine for one minute before application to workpiece to determine if machine is working properly and safely before work begins.
- Always disconnect power supply before changing abrasive/accessory or making machine adjustments.
- Inspect abrasives/accessories for damage or defects prior to installation on tools.
- Please refer to Dynabrade's Warning/Safety Operating Instructions Tag (Reorder No. 95903) for more complete safety information.
- **Warning:** Hand, wrist and arm injury may result from repetitive work, motion and overexposure to vibration.

Notice

All Dynabrade motors use the highest quality parts and metals available and are machined to exacting tolerances. The failure of quality pneumatic motors can most often be traced to an unclean air supply or the lack of lubrication. Air pressure easily forces dirt or water contained in the air supply into motor bearings causing early failure. It often scores the cylinder walls and the rotor blades resulting in limited efficiency and power. Our warranty obligation is contingent upon proper use of our tools and cannot apply to equipment which has been subjected to misuse such as unclean air, wet air or a lack of lubrication during the use of this tool.

One Year Warranty

Following the reasonable assumption that any inherent defect which might prevail in a product will become apparent to the user within one year from the date of purchase, all equipment of our manufacture is warranted against defects in workmanship and materials under normal use and service. We shall repair or replace at our factory, any equipment or part thereof which shall, within one year after delivery to the original purchaser, indicate upon our examination to have been defective. Our obligation is contingent upon proper use of Dynabrade tools in accordance with factory recommendations, instructions and safety practices. It shall not apply to equipment which has been subject to misuse, negligence, accident or tampering in any way so as to affect its normal performance. Normally wearable parts such as bearings, sanding pads, rotor blades, etc., are not covered under this warranty.

Machine Number	Length Inch (mm)	Height Inch (mm)	Weight Pound (kg)	Spindle Thread	Air Flow Rate SCFM (LPM)	Sound Level	Motor HP (W)
Number	13" (330)	8-1/4" (210)	9 lbs. (4.1)	5/8"-11 male	57 (1,614)	87 dBA	2.0 (1,491)

Additional specifications: Air Inlet Thread 1/2" (13 mm) NPT • Hose Size 1/2" (13 mm) • Air Pressure 90 PSI (6.2 Bars)

Mounting Arrangement

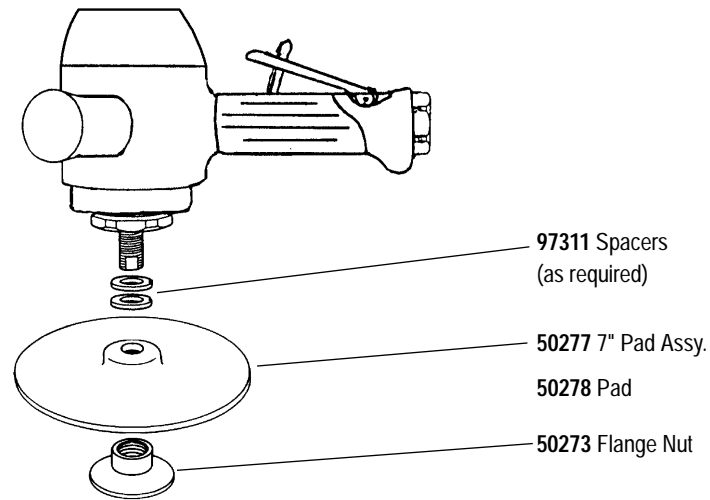

Disassembly/Assembly Instructions

Important: Manufacturer's warranty is void if tool is disassembled before warranty expires.

A Motor Repair Kit (96259) is available which contains special tools for disassembly/assembly. Please refer to parts breakdown for part identification.

Tool Disassembly:

1. Disconnect tool from power source.
2. Remove back-up pad with a 24mm wrench (P/N 95304).
3. Insert 01697 Inlet Bushing securely into vise.
4. Roll 07136 Handle Grip Back away from housing.
5. Remove 52495 Nut by using a 32mm wrench (P/N 96079).
6. Separate valve body from housing.
7. Remove 95720 Screws (4) and 01791 Washers (4) from 52461 Housing Cap. Remove housing cap and 52477 Gasket.

Motor Disassembly:

1. Grip onto governor cage assembly and pull motor assembly from housing.
Note: If motor assembly does not come out freely, gently tap tool rotor side down to "pop" motor from housing.
2. Remove governor cage assembly from 52466 Rotor (left hand thread).
3. Insert a tap pin into rear bearing plate and press the 52466 Rotor from the rear bearing plate.
4. Place motor assembly in softjaw vise.
5. Remove 01823 Washer and 01835 Shim from assembly.
6. Remove 01815 Rotor Nut with an adjustable wrench. Twist rotor nut from shaft
7. Remove 52475 Cylinder, blades (4) and spacer from rotor.
8. Remove 52472 Front Bearing Plate, front bearing and shims from 52466 Rotor. **Note:** Bearing, front bearing plate and spacer are a slip fit into rotor.
9. Press 01036 Bearing from bearing plate.

Motor disassembly complete.

Motor Reassembly:

Important: Be certain all parts are cleaned and in good repair before reassembly.

1. Place 52466 Rotor in padded vise with threaded spindle facing upwards.
2. Slip 52467 Spacer onto rotor.
3. Place .002" shim into front bearing plate as initial spacing and slip 01825 Bearing into plate. **Note:** 52471 Shim Pak contains .001" and .003" shims.
4. Install bearing/bearing plate assembly onto rotor.
5. Install 01815 Rotor Nut onto assembly.
6. Tighten rotor nut onto rotor, torque 22.5 N•m/200 in. - lbs.
7. Check clearance between rotor and bearing plate by using a .001" feeler gauge. Clearance should be at .001" to .0015". Adjust clearance by repeating steps 1-5 with different shims if necessary.
8. Once proper rotor/gap clearance is achieved, install well lubricated 52474 Blades (4) into rotor slots. Dynabrade Air Lube P/N 95842 (or equivalent) is recommended for lubrication before installation in rotor slots.
9. Install cylinder over rotor.
10. Press the 01036 Rear Bearing into 52476 Rear Bearing Plate. Press bearing/bearing plate assembly onto rotor. Be sure that pin and air slot line-up with pin hole and air inlet slot in cylinder.
11. Place the tool into a soft jaw vise and tighten the governor assembly (52478 Governor Cage) torque 9.0 N•m/80 in. - lbs. (left hand thread).
12. Place 01835 Shim and 01823 Washer into housing.

(continued on next page)

Disassembly/Assembly Instructions (continued)

13. Install **52477** Gasket and **52461** Housing Cap with **95720** screws and **01791** Washers, tighten screws to 9 N·m/80 in. - lbs.
14. Place complete motor assembly into housing. Be sure motor drops all the way into housing.
15. Motor adjustment must now be checked. With motor housing still mounted in vise, pull end of rotor and twist (10-15 lbs. force), rotor should turn freely without drag. If drag or rub is felt, then increase preload or remove shim. Also, push end of rotor and twist (10-15 lbs. force), rotor should turn freely without drag. If drag or rub is felt, then deload or add a shim.
16. Apply 2 drops of #271 Loctite® (or equivalent) to threads of adjustment bushing before tightening.
17. Slip **52491** Bushing through **52495** Nut and packing, and secure into housing.
18. Tighten **52491** Adjustment Bushing into housing torque 50 N·m/450 in. - lbs. Tighten valve body into housing.
19. Secure inlet bushing into vise. Place **52495** Nut and **01746** O-Ring onto valve body. Swivel **52494** Valve Body to desired throttle lever position.
20. Tighten **52495** Nut to 45 N·m/400 in. - lbs. Roll **07136** Grip back into place.

Tool assembly is complete. Please allow 30 minutes for adhesives to cure before operating tool.

Important: Motor should now be tested for proper operation at 90 PSI. If motor does not operate properly or operates at a higher RPM than marked on the tool, the tool should be serviced to correct the cause before use. Before operating, place 2-3 drops of Dynabrade Air Lube (P/N **95842**) directly into air inlet with throttle lever depressed. Operate tool for thirty seconds to determine if tool is operating properly and to allow lubricating oils to properly penetrate motor. Loctite® is a registered trademark of Loctite Corp.

Optional Accessories



Dynamswivel®

Swivels 360° at two locations which allows an air hose to drop straight to the floor, no matter how the tool is held.

- **95460** 1/4" NPT
- **95461** 3/8" NPT
- **95462** 1/2" NPT



96259 Motor Tune-Up Kit:

- Includes assorted parts to help maintain motor in tip-top shape.

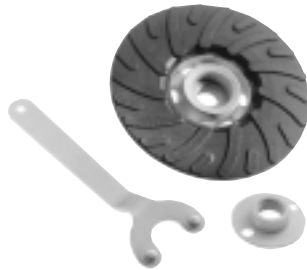

50283 – 7" Back-up Pad Assembly, 8,500 RPM max.

- Hard density.
- Includes **50287** Flange Nut.
- Accepts abrasive discs with 7/8" center hole.
- **96038** Spanner Wrench optional.

Wrenches



95303 – 1/4" Hex Wrench



95304 – 24mm Open-End
96079 – 32mm Open-End



sales@alcornindustrial.com
www.alcornindustrial.com
(800) 317-4775



Visit our new Web Site via Industry.Net MROP On-Line: <http://www.dynabrade.industry.net>

E-Mail: DynaTalk@aol.com

DYNABRADE, INC., 8989 Sheridan Drive • Clarence, NY 14031-1490 • Phone: (716) 631-0100 • Fax: 716-631-2073 • International Fax: 716-631-2524
DYNABRADE EUROPE S.à.r.l., Zone Artisanale • L-5485 Wormeldange—Haut, Luxembourg • Telephone: 352 76 84 94 • Fax: 352 76 84 95

©DYNABRADE, INC., 1997

PRINTED IN USA