

587W Clinical Care Recliner

Operating Instructions



587W-INS-LAB

© Graham-Field Health Products 2005

**IMPORTANT: READ THIS MANUAL BEFORE OPERATING
YOUR ORTHO-BIOTIC CLINICAL CARE RECLINER**

WARNINGS

- ⚠ **Warning: Periodically inspect all parts and replace as needed.**
- ⚠ **Warning: Occupant weight should not exceed 450 lbs.**
- ⚠ **Warning: Do not use near an open flame, as the chair may be a "combustion source".**
- ⚠ **Warning: Caster wheels should be locked during occupant transfer.**

CARE & MAINTENANCE

Every three months:

- Check and clean casters • tighten nuts • check brakes on casters •
- check and clean lock recline mechanism •

Check recliner mechanism for operation in all positions with assistant seated in recliner.

For upholstery maintenance and stain removal, the following hints will be helpful:

Ordinary Dirt: Wash with warm water and a mild soap or detergent.

Stubborn Dirt: Using a soft bristle brush, follow directions above.

Ground-in Dirt: Scrub with powdered cleanser or similar detergent.

Chewing Gum: Scrape carefully; remove with kerosene or naphtha.

Nail Polish and Remover: Blot immediately to prevent damage.

Ball Point Pen: Blot immediately with a white cloth dampened in water or mineral oil.

Paint, Shoe Polish, Heel Marks: Remove immediately! Use a white cloth dampened in kerosene, naphtha or turpentine. Do not use paint remover or liquid brush cleaners.

Tars, Asphalt, Creosote: Remove to prevent staining. Clean area with kerosene or naphtha.

Caution: When using kerosene or naphtha, do so in a well ventilated area and keep away from fire and flame.

Waxing and Refinishing: Improves wearability. Use any quality paste wax.

Excrement: Remove immediately! Clean with a diluted solution of 10% (or less) of bleach or Clorox.

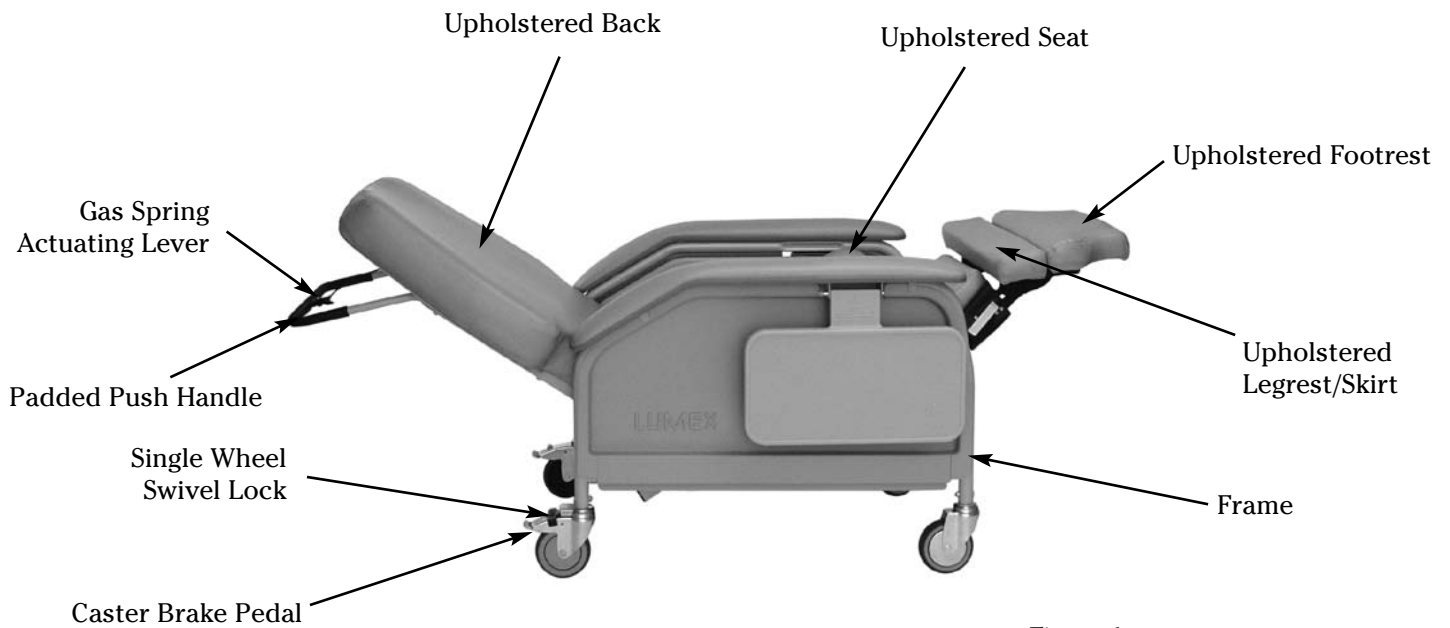

Figure 1

After removing all components from the carton, engage the two caster locks before beginning assembly.

Figure 2 shows the location for clevis pins and 4 bridge clips. Remove all the above from the back brace.

Note: Center Clevis Pins are 5/16" diameter; outside Clevis Pins are 3/8" diameter.

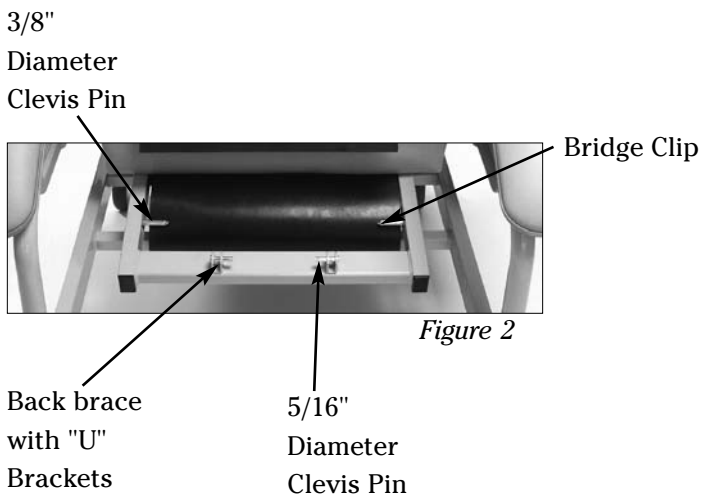

Figure 2

UPHOLSTERED BACK ASSEMBLY

1. Remove cardboard shipping retainers from around Gas Spring Cylinder. Rotate the hinge on the gas spring so that it is perpendicular to the upholstered back. (Fig. 3)

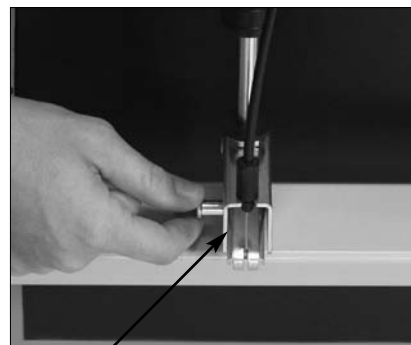

Figure 3

2. Lift the upholstered back from the sides and place it horizontally with the upright back tubes resting on the recliner frame. (Fig. 4)

3. Undo hook and rings on both side panels, both sides so mounting holes are exposed. Align the holes on the upright back tubes of the upholstered back with the holes on the seat frame. Replace the 3/8" diameter clevis pins through the mounting holes.

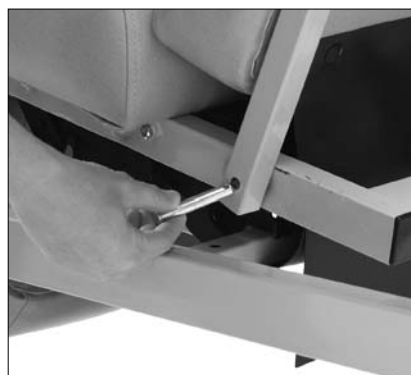

Figure 4

4. Secure the two clevis pins by replacing the bridge clips. (Fig. 5)

5. Raise the upholstered back to vertical position. Tuck the plastic skirt at rear of upholstered back behind cross brace of seat frame. Align the hinge at the bottom of the gas spring with the holes in the "U" bracket in the center of the seat frame cross brace. While holding the back with one hand, secure the gas spring hinge to the "U" bracket by replacing the 5/16" diameter clevis pin with the other hand. Secure the clevis pin by replacing the bridge clip. (Both gas spring cylinders. Fig. 3)

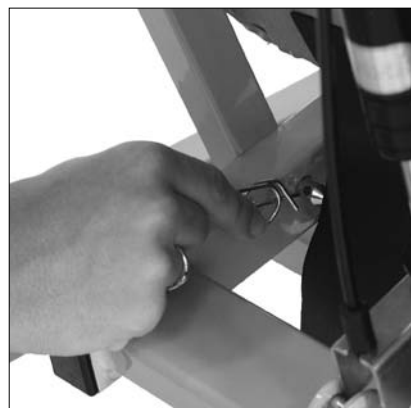

Figure 5

6. Pull side panels down with in side frames, left and right, and fasten clip to rings.

CASTER OPERATION

⚠ Warning: Caster wheels must be locked except during transport.

NOTE: This chair is equipped with four swivel caster for improved maneuverability. The rear casters are also equipped with locking features.

Lock: To prevent the rear casters from swiveling and wheel turning, step on the rear pedal of the caster until it latches.

Unlock: Step on middle button to unlatch.

SWIVEL LOCK PEDAL OPERATION

NOTE: The swivel lock feature will aid the chair in rolling straight.

Lock: To engage, push down on black swivel lock pedal and roll the recliner forward.

Unlock: Lift on the side of the pedal.

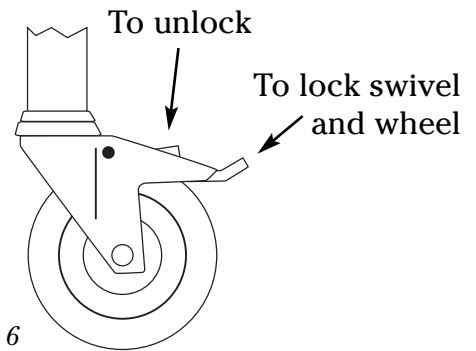

Figure 6

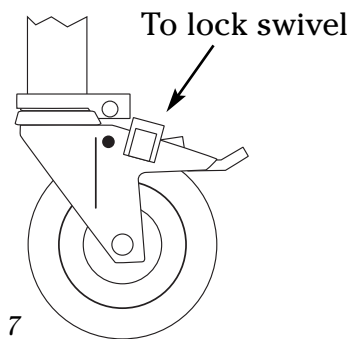

Figure 7

TABLE OPERATION

To Raise: Raise table all the way up and slide in toward the armrest until tabs engage slots in mount bracket. Press down lightly on table to ensure lock tabs are engaged.

To Lower: Lift table up until tabs disengage slots and pull table away from armrest. Lower table to self-storing position.

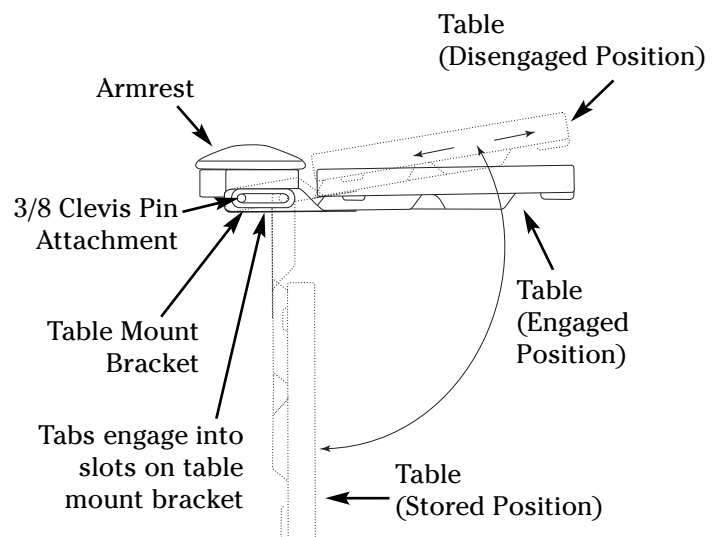

Figure 8

SEAT POSITIONING

Reclining by patient: To place recliner in standard seated position, recline position No. 1, or recline position No.2. Place hands on armrest and push body against chair back. Legrest will automatically adjust to each recline position.

Reclining by attendant: Stand at either side of recliner. Grasp armrest with one hand and padded push handle with the other hand. To lower, push back on padded push handle. To raise, pull forward on padded push handle.

DIALYSIS RECLINE POSITION

Note: For gas spring to operate properly, a person of 150 lbs. minimum should be sitting in chair.

To place chair in dialysis position: Place chair in first recline position. Grasp the push handle with one hand while actuating the lever with the other, slowly guide the back down to the desired position and release lever.

To return to seated position: To bring recliner back to seated. No.1 or No. 2 position: Actuate lever. Slowly guide the back up fully and release the lever. Return patient to the desired position by pushing upward on padded push handle.

SHOCK POSITION

To attain shock position from any position: Grasp the push handle with one hand while actuating the lever with the other, slowly guide the back down fully and release the lever.

To return to seated position: Refer to paragraph two of dialysis position.



Upright Position



Recline Position No. 1



Recline Position No. 2



Dialysis Position



Shock Position

GAS SPRING TROUBLESHOOTING GUIDE

Gas Springs have been preadjusted at factory

The gas spring on your recliner provides counterbalancing forces, and is self-locking for infinite, precise positioning. Unlocking the gas spring is controlled by actuating the lever on the padded push handle on the back of the recliner. When the lever is actuated it pulls on the cable

which in turn pulls on a hinge, depressing a button at the end of the gas spring rod. If the gas spring does not unlock when the lever is actuated, or remains permanently unlocked when the lever, cable must be adjusted.

ADJUSTING CABLE TENSION:

Note: For gas spring to operate properly, a person of 150 lbs. minimum should be sitting in chair.

Note: If gas spring does need adjustment, adjust only that gas spring attached to the actuating lever and cable.

1. Remove the one screw which secures the cable to the upholstered back. Remove the gas spring from the recliner by disassembling the two bridge pins and clevis pins.
2. Lower the back until it rests on the stop bars on the recliner frame. Loosen the lock nut on the gas spring.
3. Hold the hinge assembly while turning the gas spring until the cable just becomes taut. Back off the gas spring an additional 1/2 turn.

NOTE: If the gas spring was not unlocking when the lever was actuated, the gas spring will have to be turned clockwise. If the gas spring was not locking when the lever was released, the gas spring will have to be turned counter-clockwise.

4. Retighten the lock nut.
5. Reassemble the gas spring to the back of the recliner by replacing the clevis pins, bridge pins, and screw.
6. Actuate the recliner in accordance with the operating instructions to verify correct adjustment.

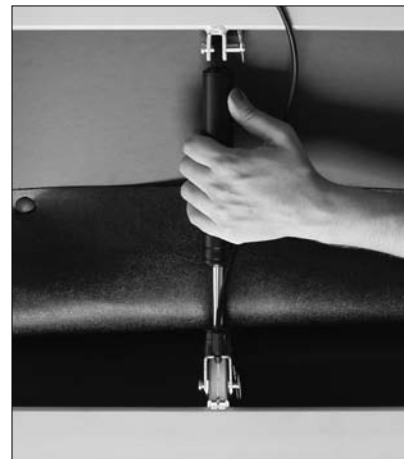

Figure 9



Figure 10

U.S.A., Corporate Headquarters:

Graham-Field Health Products
2935 Northeast Parkway
Atlanta, Georgia 30360
telephone: 800-347-5678, 770-447-1609
fax: 800-726-0601, 678-291-3232



<http://www.grahamfield.com>